

PARTS LIST					
ITEM	QTY	PART NO.	PART DESCRIPTION	UNIT WT.	NET WT.
1	3	VFA12-XD-A4	HEAVY S1-12-4 12' NOMINAL SECTOR FRAME W/ 4 MAST PIPES	1039.13	3117.38
TOTAL WT. #					3117.38

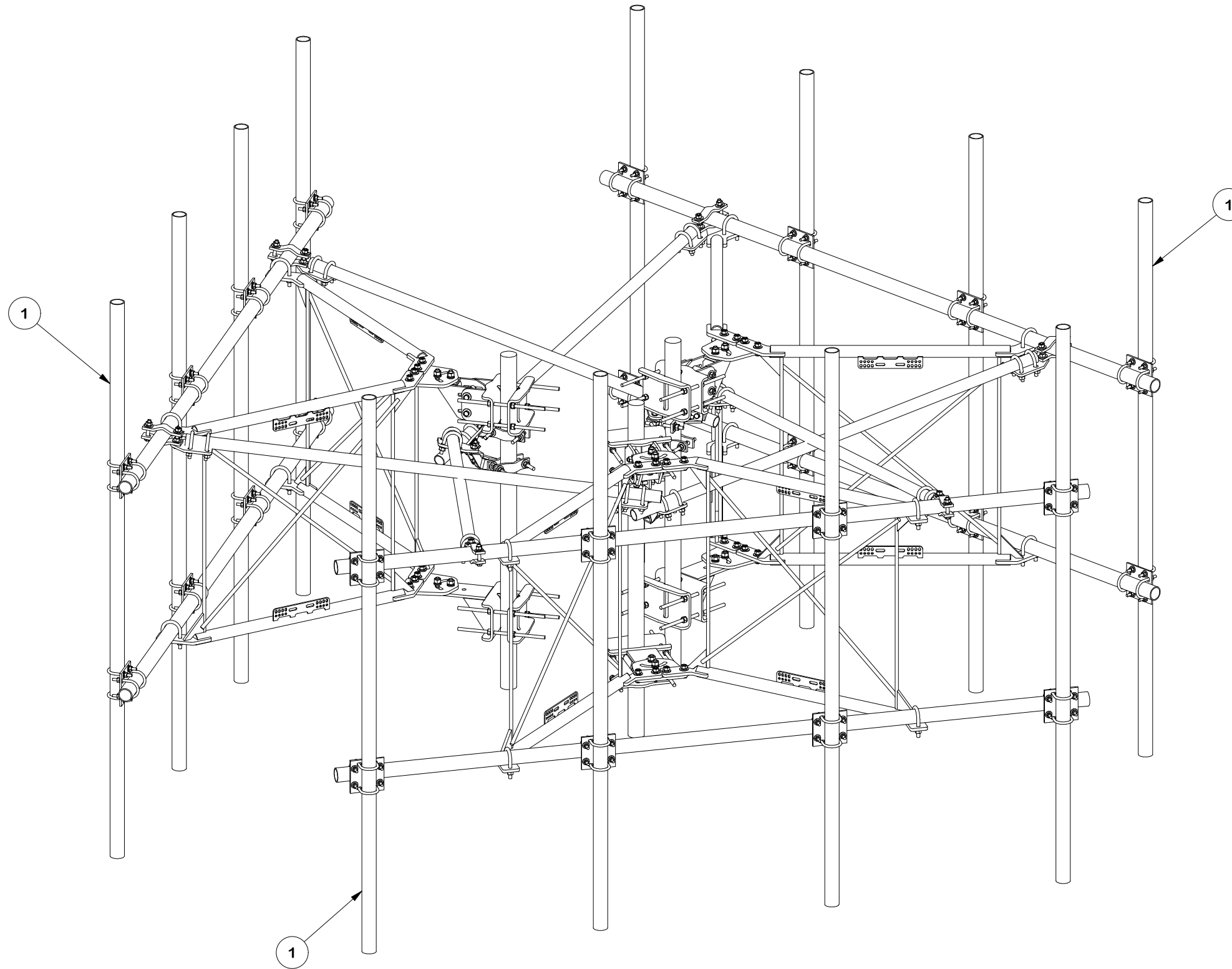

TOLERANCE NOTES

TOLERANCES ON DIMENSIONS, UNLESS OTHERWISE NOTED ARE:
 SAWED, SHEARED AND GAS CUT EDGES ($\pm 0.030"$)
 DRILLED AND GAS CUT HOLES ($\pm 0.030"$) - NO CONING OF HOLES
 LASER CUT EDGES AND HOLES ($\pm 0.010"$) - NO CONING OF HOLES
 BENDS AND ANGLES ARE $\pm 1/2$ DEGREE
 ALL OTHER MACHINING ($\pm 0.030"$)
 ALL OTHER ASSEMBLY ($\pm 0.060"$)

PATENT INFORMATION: WWW.SITEPRO1.COM/PATENTS

PROPRIETARY NOTE:
 THE DATA AND TECHNIQUES CONTAINED IN THIS DRAWING ARE PROPRIETARY INFORMATION OF VALMONT INDUSTRIES AND CONSIDERED A TRADE SECRET. ANY USE OR DISCLOSURE WITHOUT THE CONSENT OF VALMONT INDUSTRIES IS STRICTLY PROHIBITED.

DESCRIPTION
HEAVY S3-12-4
3 - 12' NOMINAL SECTOR FRAME KIT WITH
SELF-SUPPORTED / GUYED ATTACHMENT

CPD NO.	DRAWN BY	ENG. APPROVAL
NCS	ADB 8/19/2025	8/22/2025
CLASS	DRAWING USAGE	CHECKED BY
87	CUSTOMER	JET 8/22/2025



Engineering Support Team:
 sp1engineering@valmont.com

A valmont COMPANY

PART NO.	VFA12-XD3-A12
DWG. NO.	VFA12-XD3-A12

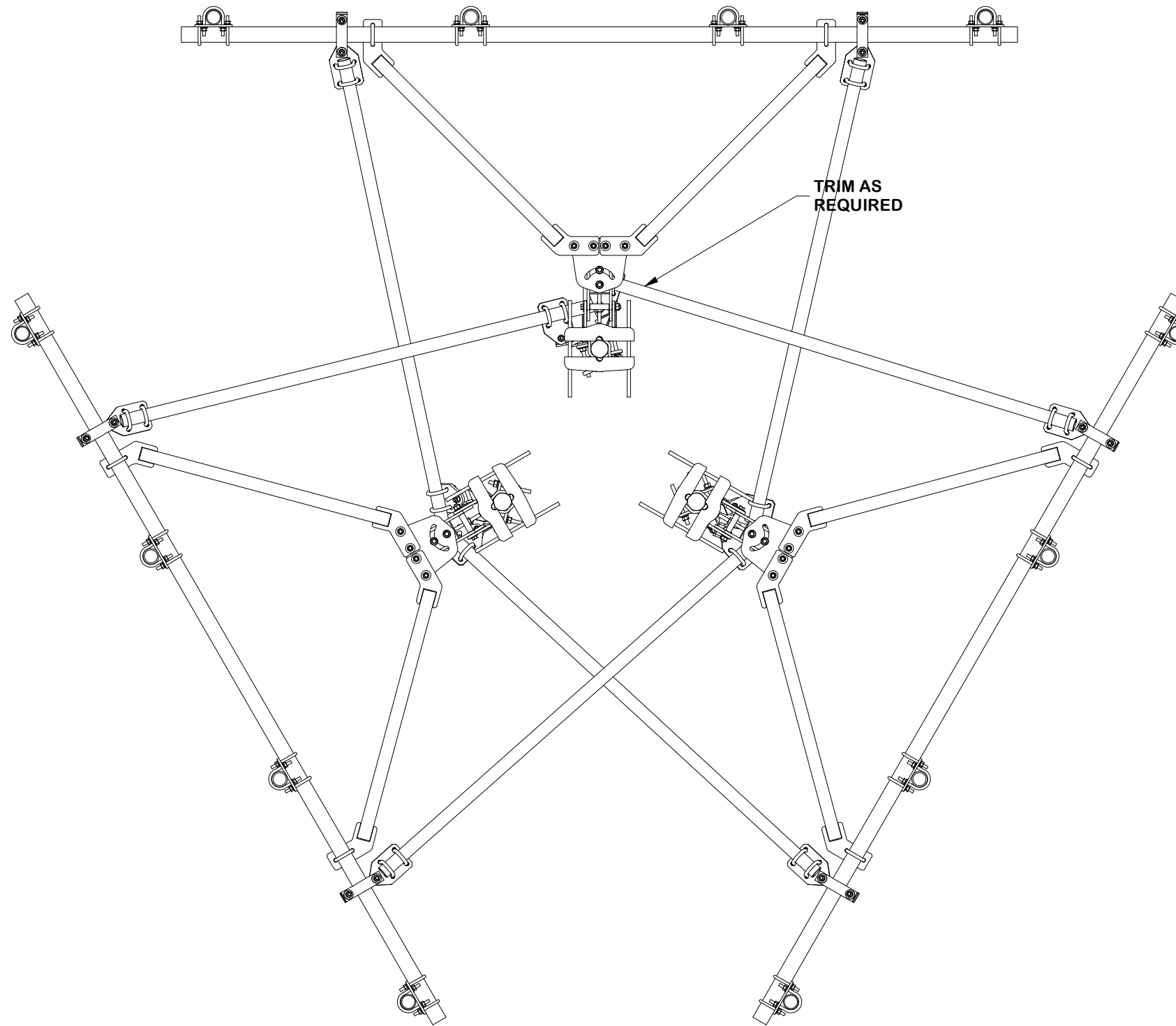

TOLERANCE NOTES

TOLERANCES ON DIMENSIONS, UNLESS OTHERWISE NOTED ARE:
 SAWED, SHEARED AND GAS CUT EDGES ($\pm 0.030"$)
 DRILLED AND GAS CUT HOLES ($\pm 0.030"$) - NO CONING OF HOLES
 LASER CUT EDGES AND HOLES ($\pm 0.010"$) - NO CONING OF HOLES
 BENDS AND ANGLES ARE $\pm 1/2$ DEGREE
 ALL OTHER MACHINING ($\pm 0.030"$)
 ALL OTHER ASSEMBLY ($\pm 0.060"$)

PATENT INFORMATION: WWW.SITEPRO1.COM/PATENTS

PROPRIETARY NOTE:
 THE DATA AND TECHNIQUES CONTAINED IN THIS DRAWING ARE PROPRIETARY INFORMATION OF VALMONT INDUSTRIES AND CONSIDERED A TRADE SECRET. ANY USE OR DISCLOSURE WITHOUT THE CONSENT OF VALMONT INDUSTRIES IS STRICTLY PROHIBITED.

DESCRIPTION
HEAVY S3-12-4
3 - 12' NOMINAL SECTOR FRAME KIT WITH
SELF-SUPPORTED / GUYED ATTACHMENT

CPD NO. NCS	DRAWN BY ADB 8/19/2025	ENG. APPROVAL 8/22/2025
CLASS 87	SUB 02	DRAWING USAGE CUSTOMER
	CHECKED BY JET 8/22/2025	



Engineering Support Team:
 sp1engineering@valmont.com

A valmont COMPANY

PART NO. VFA12-XD3-A12	PAGE 2 OF 17
DWG. NO. VFA12-XD3-A12	

PARTS LIST						
ITEM	QTY	PART NO.	PART DESCRIPTION	LENGTH	UNIT WT.	NET WT.
1	2	X-VXDW45	XTREME DUTY 45" VERTICAL SUPPORT ARM		100.07	200.13
2	1	BCAM-HD	HEAVY DUTY BOLT CALIBRATED ANGLE MAINSTAY		147.01	147.01
3	2	SPTB	SLIDING TIE-BACK ASSEMBLY KIT		91.18	182.36
4	1	VFAPL4-K	HD FRAME PIVOT PLATE KIT		39.25	39.25
5	2	P30156	2-7/8" X 156" (2-1/2" SCH. 40) GALVANIZED PIPE	156 in	80.01	160.03
6	4	P30120	2-7/8" x 120" (2-1/2" SCH. 40) GALVANIZED PIPE	120 in	58.07	232.26
7	8	SCX23-K	CROSSOVER PLATE KIT 2-7/8" X 2-7/8"		9.00	71.97
8	4	X-UB5300	5/8" X 3" X 5-1/4" X 2-1/2" U-BOLT	5 1/4 in	1.22	4.87
9	8	G58LW	5/8" HDG LOCKWASHER		0.03	0.21
10	8	G58NUT	5/8" HDG HEAVY 2H HEX NUT		0.13	1.04
					TOTAL WT. #	1049.71

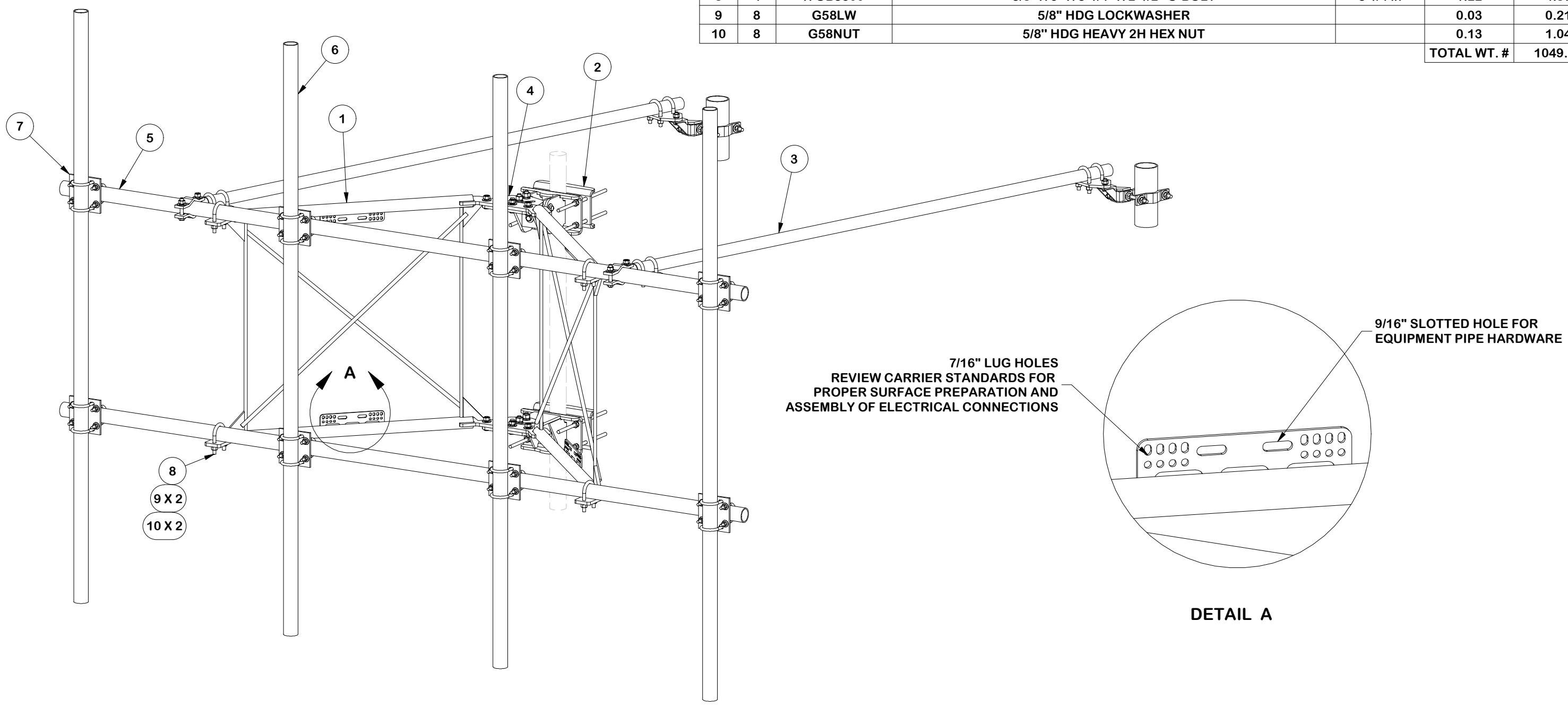

TOLERANCE NOTES

TOLERANCES ON DIMENSIONS, UNLESS OTHERWISE NOTED ARE:
 SAWED, SHEARED AND GAS CUT EDGES ($\pm 0.030"$)
 DRILLED AND GAS CUT HOLES ($\pm 0.030"$) - NO CONING OF HOLES
 LASER CUT EDGES AND HOLES ($\pm 0.010"$) - NO CONING OF HOLES
 BENDS AND ANGLES ARE $\pm 1/2$ DEGREE
 ALL OTHER MACHINING ($\pm 0.030"$)
 ALL OTHER ASSEMBLY ($\pm 0.060"$)

PATENT INFORMATION: WWW.SITEPRO1.COM/PATENTS

PROPRIETARY NOTE:
 THE DATA AND TECHNIQUES CONTAINED IN THIS DRAWING ARE PROPRIETARY INFORMATION OF VALMONT INDUSTRIES AND CONSIDERED A TRADE SECRET. ANY USE OR DISCLOSURE WITHOUT THE CONSENT OF VALMONT INDUSTRIES IS STRICTLY PROHIBITED.

DESCRIPTION
HEAVY S3-12-4
3 - 12' NOMINAL SECTOR FRAME KIT WITH SELF-SUPPORTED / GUYED ATTACHMENT

CPD NO. NCS	DRAWN BY ADB 8/19/2025	ENG. APPROVAL 8/22/2025
CLASS 87	SUB 02	DRAWING USAGE CUSTOMER
CHECKED BY JET 8/22/2025		

SITE PRO 1
 Engineering Support Team:
 sp1engineering@valmont.com
 A valmont COMPANY

PART NO. VFA12-XD-A4	3 OF 17 PAGE
DWG. NO. VFA12-XD3-A12	

**NOTE: ALL COMPONENTS AND
HARDWARE SOLD SEPERATELY**

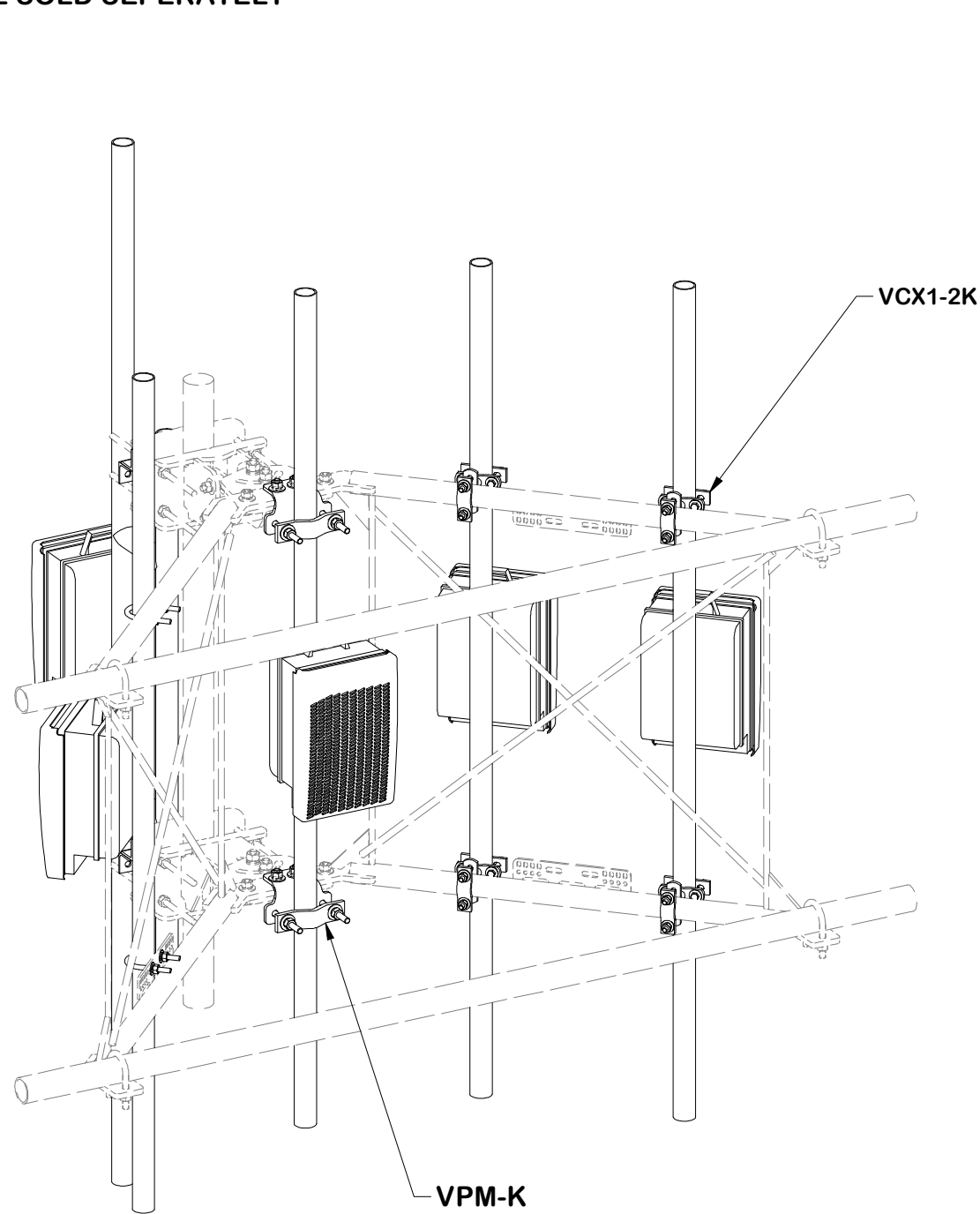

FRONT ISO

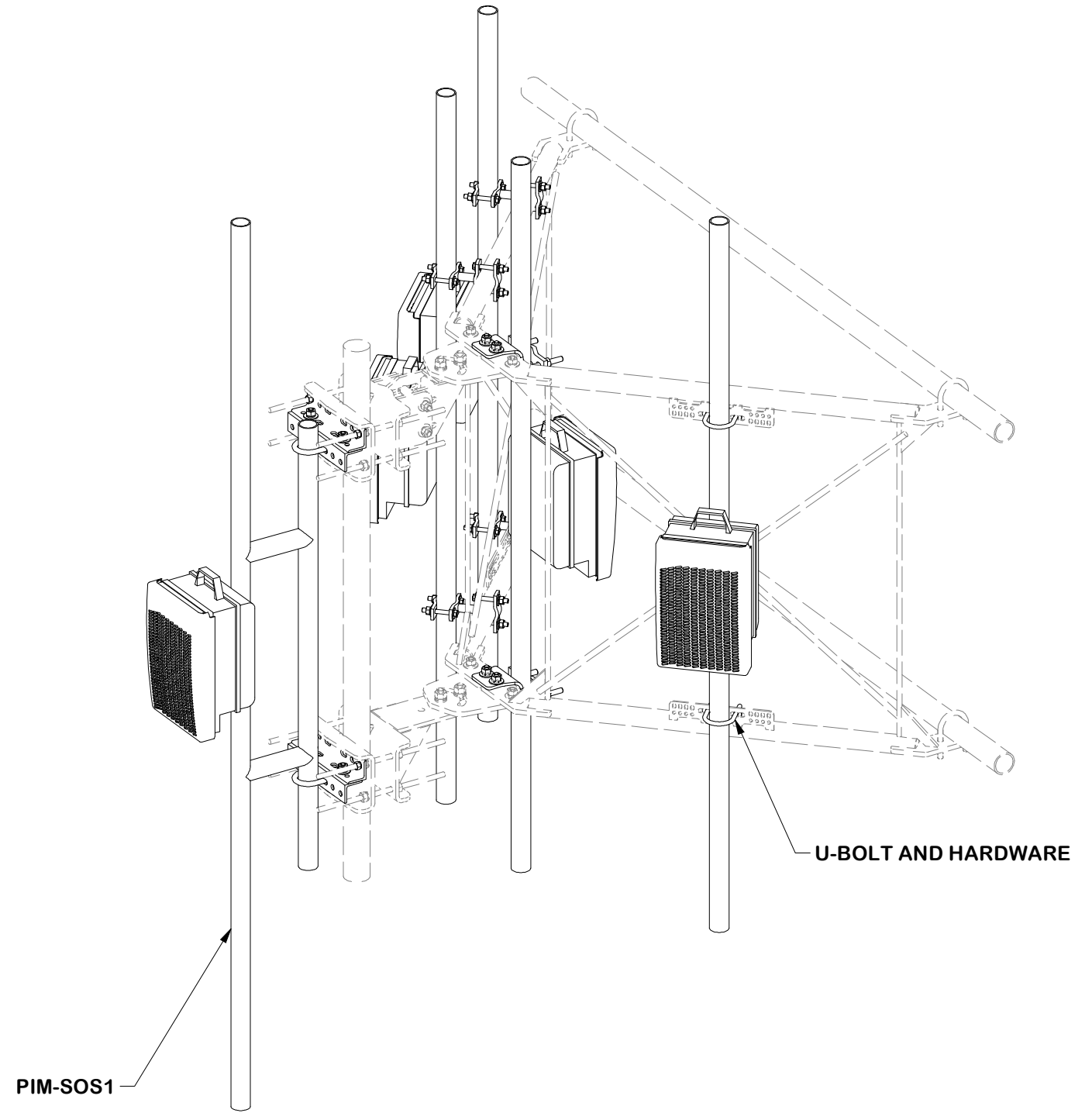

REAR ISO

TOLERANCE NOTES

TOLERANCES ON DIMENSIONS, UNLESS OTHERWISE NOTED ARE:
 SAWED, SHEARED AND GAS CUT EDGES ($\pm 0.030"$)
 DRILLED AND GAS CUT HOLES ($\pm 0.030"$) - NO CONING OF HOLES
 LASER CUT EDGES AND HOLES ($\pm 0.010"$) - NO CONING OF HOLES
 BENDS AND ANGLES ARE $\pm 1/2$ DEGREE
 ALL OTHER MACHINING ($\pm 0.030"$)
 ALL OTHER ASSEMBLY ($\pm 0.060"$)

PATENT INFORMATION: WWW.SITEPRO1.COM/PATENTS

PROPRIETARY NOTE:
 THE DATA AND TECHNIQUES CONTAINED IN THIS DRAWING ARE PROPRIETARY INFORMATION OF VALMONT INDUSTRIES AND CONSIDERED A TRADE SECRET. ANY USE OR DISCLOSURE WITHOUT THE CONSENT OF VALMONT INDUSTRIES IS STRICTLY PROHIBITED.

DESCRIPTION
**HEAVY S3-12-4
 3 - 12' NOMINAL SECTOR FRAME KIT WITH
 SELF-SUPPORTED / GUYED ATTACHMENT**

CPD NO. NCS	DRAWN BY ADB 8/19/2025	ENG. APPROVAL 8/22/2025
CLASS 87	SUB 02	DRAWING USAGE CUSTOMER
	CHECKED BY JET 8/22/2025	



Engineering
 Support Team:
 sp1engineering@valmont.com

A valmont COMPANY

PART NO. VFA RRU REF	PAGE 4 OF 17
DWG. NO. VFA12-XD3-A12	

3 ANTENNA SECTOR FRAME LAYOUT

NOTE: FOR RRU OVER 30" WIDTH
CONSIDER STANDOFF CROSSOVERS
(P/N VCX1-2K OR RRU-FU2 ORDER SEPARATELY)

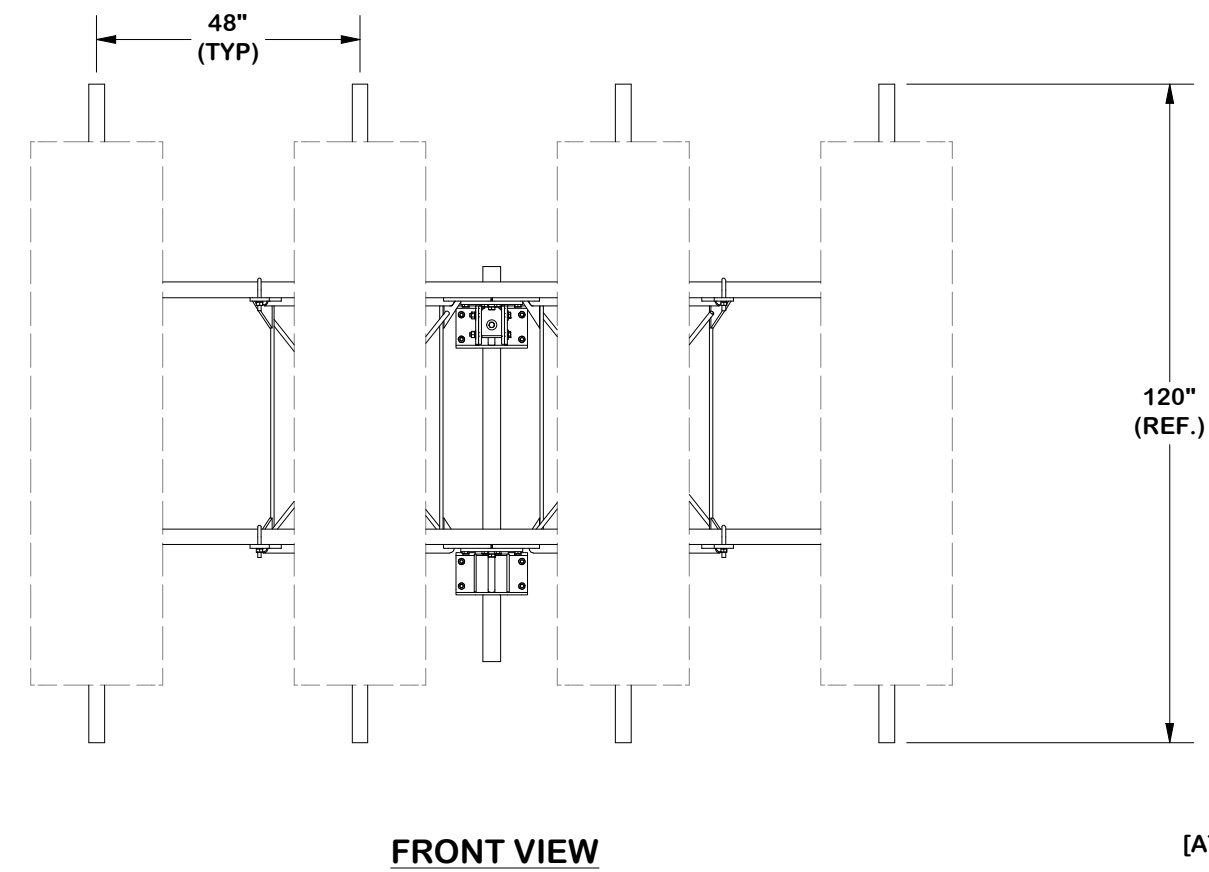
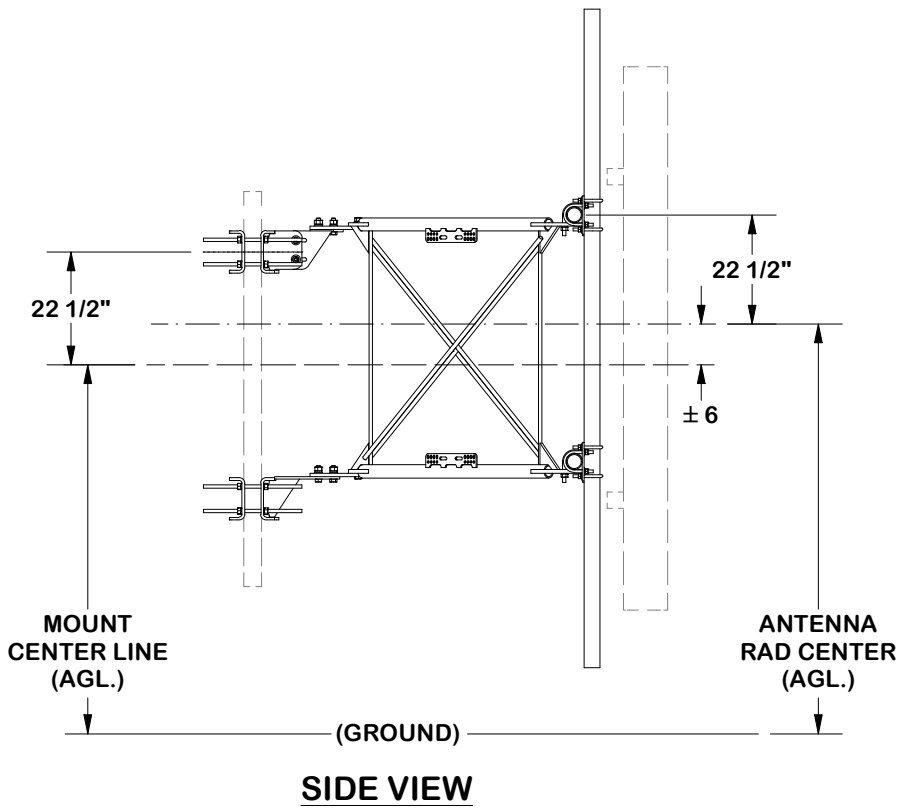
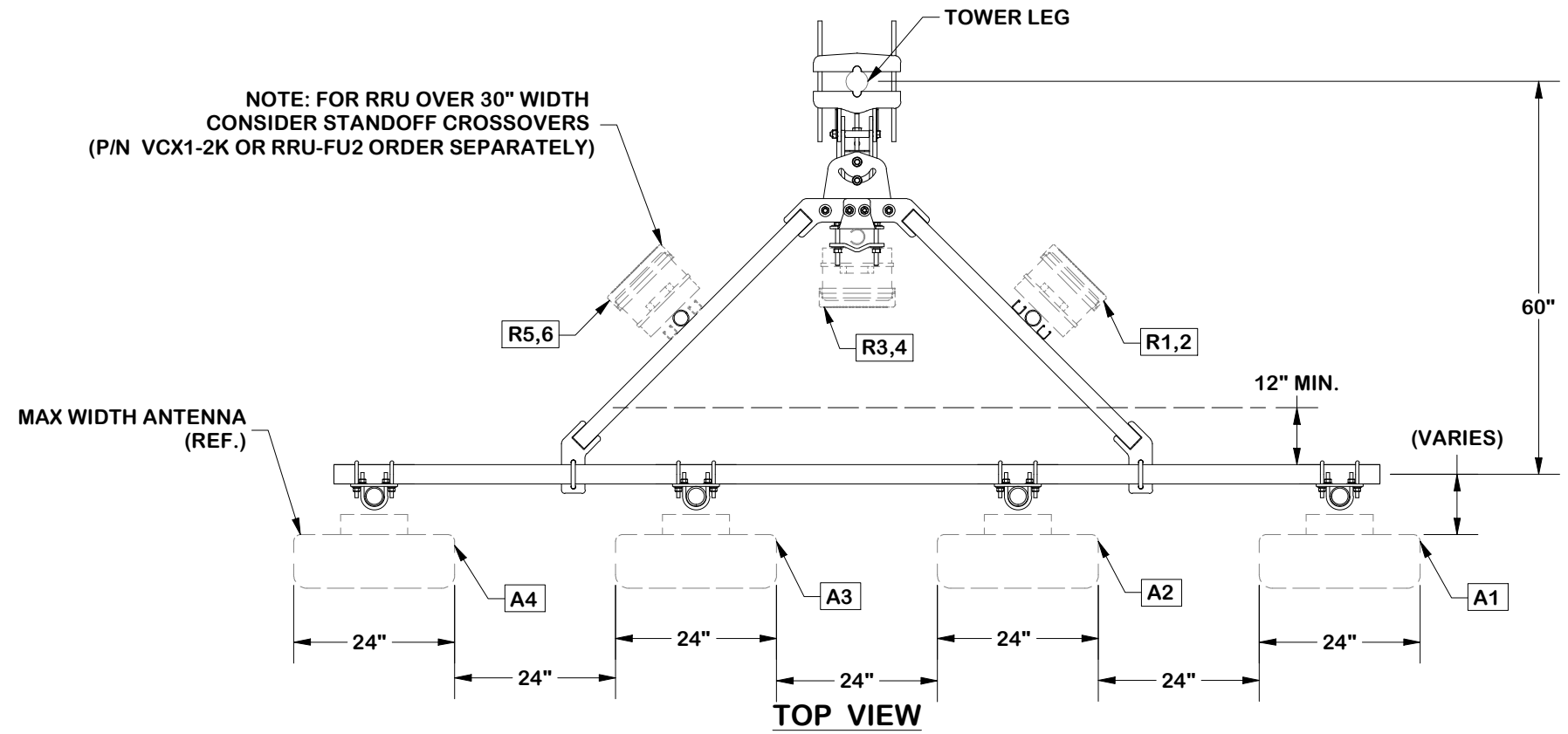

[ATT-790-202-083 MACRO BUILD COMPLIANT]

TOLERANCE NOTES

TOLERANCES ON DIMENSIONS, UNLESS OTHERWISE NOTED ARE:
SAWED, SHEARED AND GAS CUT EDGES ($\pm 0.030"$)
DRILLED AND GAS CUT HOLES ($\pm 0.030"$) - NO CONING OF HOLES
LASER CUT EDGES AND HOLES ($\pm 0.010"$) - NO CONING OF HOLES
BENDS AND ANGLES ARE $\pm 1/2$ DEGREE
ALL OTHER MACHINING ($\pm 0.030"$)
ALL OTHER ASSEMBLY ($\pm 0.060"$)

PATENT INFORMATION: WWW.SITEPRO1.COM/PATENTS

PROPRIETARY NOTE:
THE DATA AND TECHNIQUES CONTAINED IN THIS DRAWING ARE PROPRIETARY INFORMATION OF VALMONT INDUSTRIES AND CONSIDERED A TRADE SECRET. ANY USE OR DISCLOSURE WITHOUT THE CONSENT OF VALMONT INDUSTRIES IS STRICTLY PROHIBITED.

DESCRIPTION

HEAVY S3-12-4
3 - 12' NOMINAL SECTOR FRAME KIT WITH
SELF-SUPPORTED / GUYED ATTACHMENT

CPD NO.

NCS

CLASS

87

DRAWN BY

ADB 8/19/2025

DRAWING USAGE

CUSTOMER

ENG. APPROVAL

8/22/2025

CHECKED BY

JET 8/22/2025

PART NO.

VFA12-XD-A4

DWG. NO.

VFA12-XD3-A12



A valmont COMPANY

Engineering
Support Team:
sp1engineering@valmont.com

MONOPOLE CORNER LAYOUT

NOTE: MDFCC SHOWN AS REFERENCE

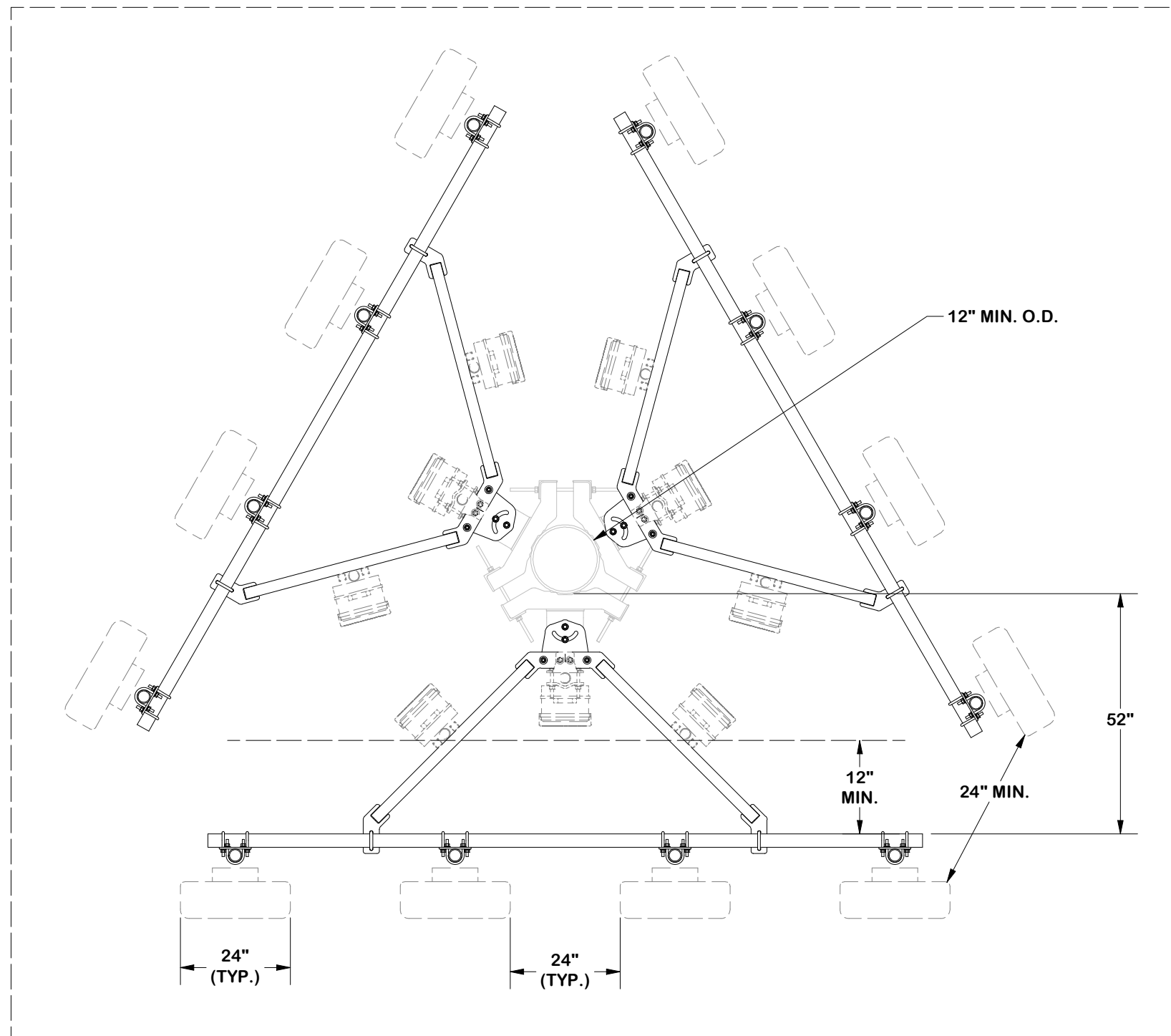

[ATT-790-202-083 MACRO BUILD COMPLIANT]

NOTE: TIEBACKS OMITTED FOR CLARITY

TOLERANCE NOTES

TOLERANCES ON DIMENSIONS, UNLESS OTHERWISE NOTED ARE:
 SAWED, SHEARED AND GAS CUT EDGES ($\pm 0.030"$)
 DRILLED AND GAS CUT HOLES ($\pm 0.030"$) - NO CONING OF HOLES
 LASER CUT EDGES AND HOLES ($\pm 0.010"$) - NO CONING OF HOLES
 BENDS AND ANGLES ARE $\pm 1/2$ DEGREE
 ALL OTHER MACHINING ($\pm 0.030"$)
 ALL OTHER ASSEMBLY ($\pm 0.060"$)

PATENT INFORMATION: WWW.SITEPRO1.COM/PATENTS

PROPRIETARY NOTE:
 THE DATA AND TECHNIQUES CONTAINED IN THIS DRAWING ARE PROPRIETARY INFORMATION OF VALMONT INDUSTRIES AND CONSIDERED A TRADE SECRET. ANY USE OR DISCLOSURE WITHOUT THE CONSENT OF VALMONT INDUSTRIES IS STRICTLY PROHIBITED.

DESCRIPTION
HEAVY S3-12-4
3 - 12' NOMINAL SECTOR FRAME KIT WITH SELF-SUPPORTED / GUYED ATTACHMENT

CPD NO. NCS	DRAWN BY ADB 8/19/2025	ENG. APPROVAL 8/22/2025
CLASS 87	SUB 02	DRAWING USAGE CUSTOMER
CHECKED BY JET 8/22/2025		



A valmont COMPANY

Engineering Support Team:
 sp1engineering@valmont.com

PART NO. CORNER LAYOUT
DWG. NO. VFA12-XD3-A12

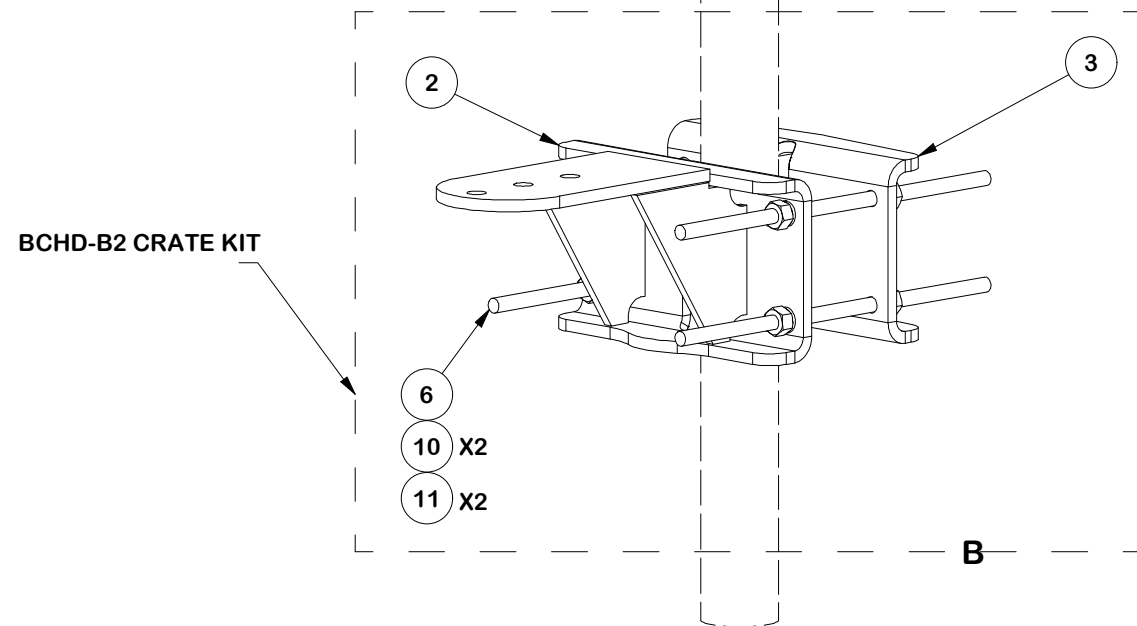
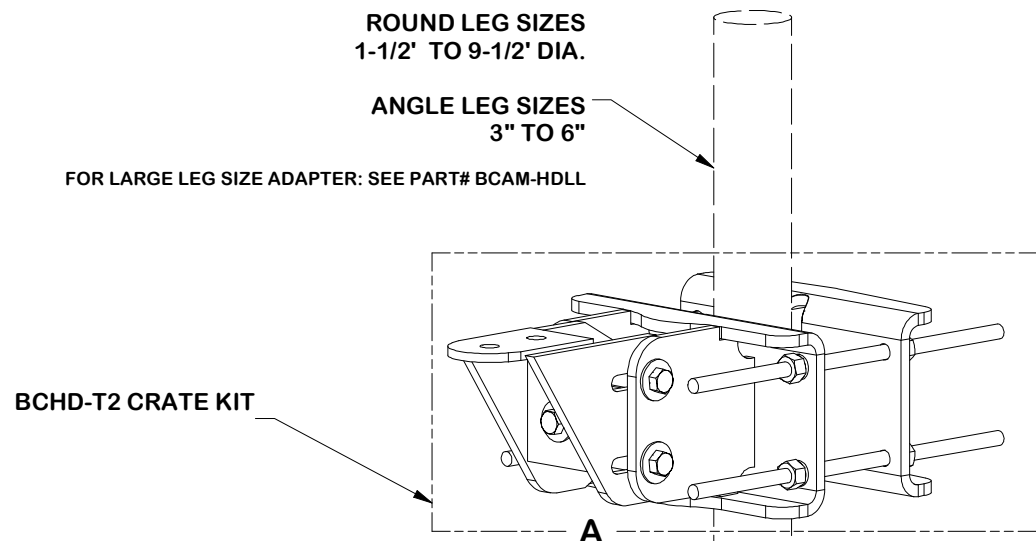

PARTS LIST						
ITEM	QTY	PART NO.	PART DESCRIPTION	LENGTH	UNIT WT.	NET WT.
1	1	X-HDCAMTBW	CLAMP WELDMENT FOR BCAM-HD		33.86	33.86
2	1	X-MHTPHD	MULTI-HOLE TAPER PLATE WELDMENT		36.24	36.24
3	2	X-LCBP4	BENT BACKING PLATE	13 in	20.04	40.09
4	1	X-HDCAMSS	ANGLE ADJUSTMENT WELDMENT FOR BCAM-HD		16.39	16.39
5	1	X-HDCAMSP	POSITIONING PLATE WELDMENT FOR BCAM-HD		2.58	2.58
6	8	G58R-18	5/8" x 18" THREADED ROD (HDG.)		1.57	12.54
7	2	G5807	5/8" x 7" HDG HEX BOLT GR5 FULL THREAD	7 in	0.70	1.41
8	1	G5806	5/8" x 6" HDG HEX BOLT GR5 FULL THREAD	6 in	0.62	0.62
9	5	G58FW	5/8" HDG USS FLATWASHER	1/8 in	0.07	0.35
10	18	G58LW	5/8" HDG LOCKWASHER		0.03	0.47
11	19	G58NUT	5/8" HDG HEAVY 2H HEX NUT		0.13	2.47
TOTAL WT. #						147.02

**** FOR DETAIL SEE PAGE 2****

REV	DESCRIPTION OF REVISIONS	CPD	BY	DATE
A	REPLACED C CHANNEL BRKT WITH FORMED PLATE BRKT	SP1	ADB	4/24/2018
REVISION HISTORY				

TOLERANCE NOTES

TOLERANCES ON DIMENSIONS, UNLESS OTHERWISE NOTED ARE:
 SAWED, SHEARED AND GAS CUT EDGES ($\pm 0.030"$)
 DRILLED AND GAS CUT HOLES ($\pm 0.030"$) - NO CONING OF HOLES
 LASER CUT EDGES AND HOLES ($\pm 0.010"$) - NO CONING OF HOLES
 BENDS AND ANGLES ARE $\pm 1/2$ DEGREE
 ALL OTHER MACHINING ($\pm 0.030"$)
 ALL OTHER ASSEMBLY ($\pm 0.060"$)

PATENT INFORMATION: WWW.SITEPRO1.COM/PATENTS

PROPRIETARY NOTE:
 THE DATA AND TECHNIQUES CONTAINED IN THIS DRAWING ARE PROPRIETARY INFORMATION OF VALMONT INDUSTRIES AND CONSIDERED A TRADE SECRET. ANY USE OR DISCLOSURE WITHOUT THE CONSENT OF VALMONT INDUSTRIES IS STRICTLY PROHIBITED.

DESCRIPTION			
HEAVY S3-12-4 3 - 12' NOMINAL SECTOR FRAME KIT WITH SELF-SUPPORTED / GUYED ATTACHMENT			
CPD NO.	DRAWN BY	ENG. APPROVAL	
NCS	ADB 8/19/2025	8/22/2025	
CLASS	SUB	DRAWING USAGE	CHECKED BY
87	02	CUSTOMER	JET 8/22/2025

 A valmont COMPANY		Engineering Support Team: sp1engineering@valmont.com
PART NO.		BCAM-HD
DWG. NO.		VFA12-XD3-A12

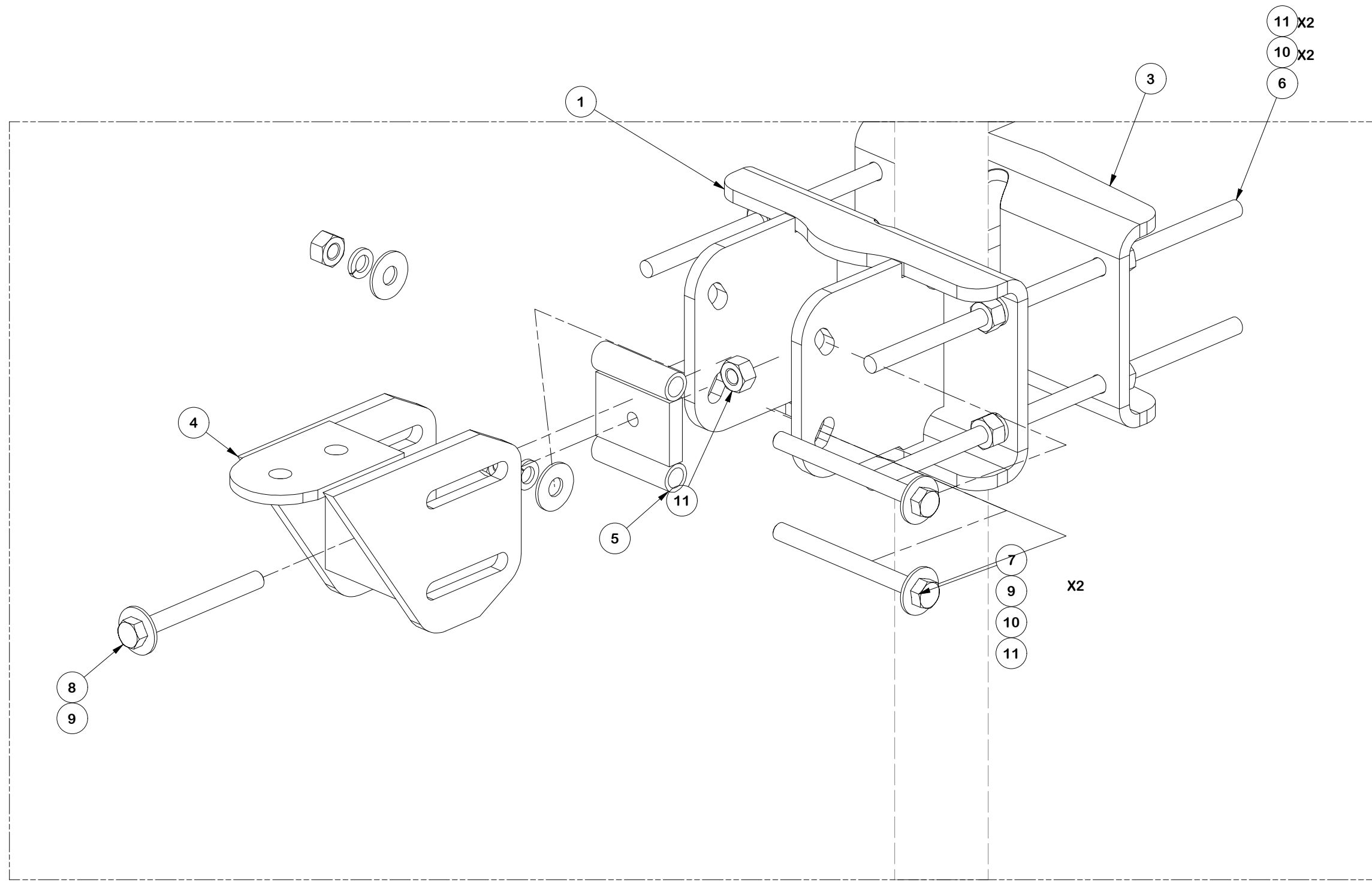

VIEW A

TOLERANCE NOTES

TOLERANCES ON DIMENSIONS, UNLESS OTHERWISE NOTED ARE:
 SAWED, SHEARED AND GAS CUT EDGES ($\pm 0.030"$)
 DRILLED AND GAS CUT HOLES ($\pm 0.030"$) - NO CONING OF HOLES
 LASER CUT EDGES AND HOLES ($\pm 0.010"$) - NO CONING OF HOLES
 BENDS AND ANGLES ARE $\pm 1/2$ DEGREE
 ALL OTHER MACHINING ($\pm 0.030"$)
 ALL OTHER ASSEMBLY ($\pm 0.060"$)

PATENT INFORMATION: WWW.SITEPRO1.COM/PATENTS

PROPRIETARY NOTE:
 THE DATA AND TECHNIQUES CONTAINED IN THIS DRAWING ARE PROPRIETARY INFORMATION OF VALMONT INDUSTRIES AND CONSIDERED A TRADE SECRET. ANY USE OR DISCLOSURE WITHOUT THE CONSENT OF VALMONT INDUSTRIES IS STRICTLY PROHIBITED.

DESCRIPTION
HEAVY S3-12-4
3 - 12' NOMINAL SECTOR FRAME KIT WITH
SELF-SUPPORTED / GUYED ATTACHMENT

CPD NO. NCS	DRAWN BY ADB 8/19/2025	ENG. APPROVAL 8/22/2025
CLASS 87	SUB 02	DRAWING USAGE CUSTOMER
	CHECKED BY JET 8/22/2025	

SITE PRO 1
 A valmont COMPANY

Engineering Support Team:
 sp1engineering@valmont.com

PART NO. BCAM-HD	PAGE 8 OF 17
DWG. NO. VFA12-XD3-A12	

ANGLE CALIBRATING PROCEDURE:

1. MEASURE TOWER TAPER AND PICK LOWER BRACKET HOLE:
 - HOLE A = -2.6° TO 2.6°
 - HOLE B = 1.6° TO 6.8°
2. USE CALIBRATING BOLT TO ADJUST FRAME TO DESIRED TAPER
3. TORQUE LOCKING BOLTS TO 100 ft.-lbs.
4. ADVANCE LOCKING NUT TO POSITIONING PLATE, THEN TIGHTEN.

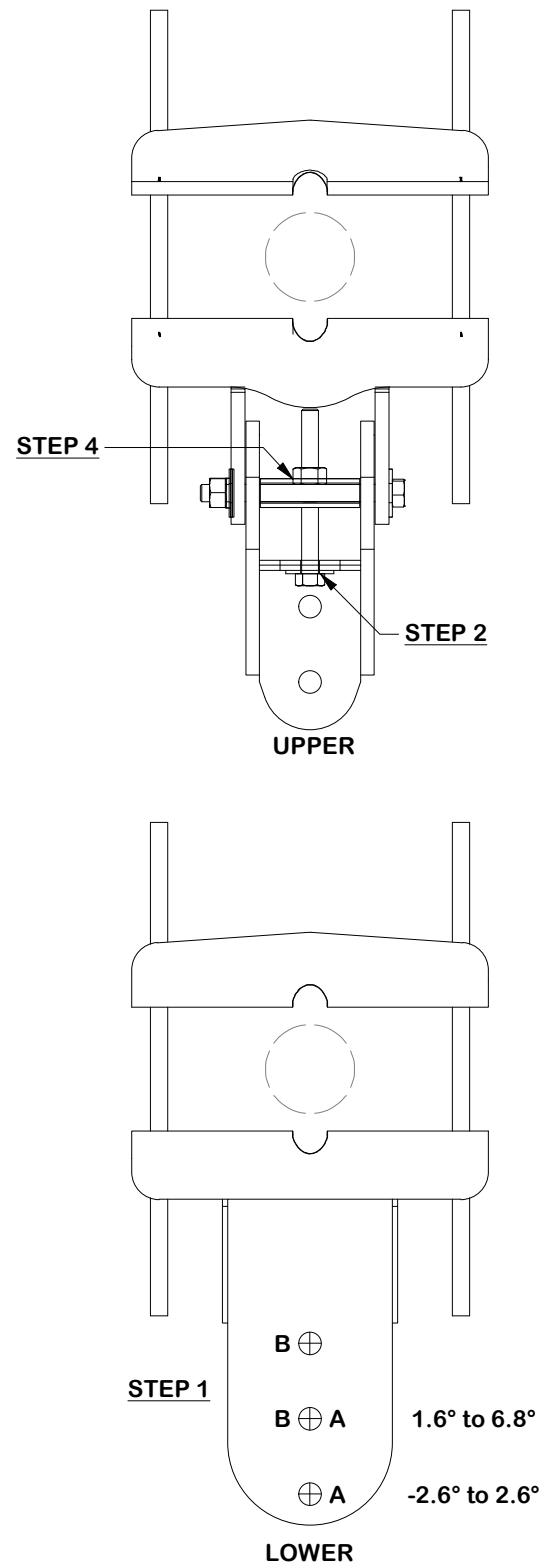

TOLERANCE NOTES

TOLERANCES ON DIMENSIONS, UNLESS OTHERWISE NOTED ARE:
 SAWED, SHEARED AND GAS CUT EDGES ($\pm 0.030"$)
 DRILLED AND GAS CUT HOLES ($\pm 0.030"$) - NO CONING OF HOLES
 LASER CUT EDGES AND HOLES ($\pm 0.010"$) - NO CONING OF HOLES
 BENDS AND ANGLES ARE $\pm 1/2$ DEGREE
 ALL OTHER MACHINING ($\pm 0.030"$)
 ALL OTHER ASSEMBLY ($\pm 0.060"$)

PATENT INFORMATION: WWW.SITEPRO1.COM/PATENTS

PROPRIETARY NOTE:
 THE DATA AND TECHNIQUES CONTAINED IN THIS DRAWING ARE PROPRIETARY INFORMATION OF VALMONT INDUSTRIES AND CONSIDERED A TRADE SECRET. ANY USE OR DISCLOSURE WITHOUT THE CONSENT OF VALMONT INDUSTRIES IS STRICTLY PROHIBITED.

DESCRIPTION
HEAVY S3-12-4
3 - 12' NOMINAL SECTOR FRAME KIT WITH SELF-SUPPORTED / GUYED ATTACHMENT



Engineering Support Team:
 sp1engineering@valmont.com

A valmont COMPANY

CPD NO. NCS	DRAWN BY ADB 8/19/2025	ENG. APPROVAL 8/22/2025
CLASS 87	SUB 02	DRAWING USAGE CUSTOMER
CHECKED BY JET 8/22/2025		

PART NO. BCAM-HD	PAGE 9 OF 17
DWG. NO. VFA12-XD3-A12	

PARTS LIST							
ITEM	QTY	PART NO.	BOX NO.	PART DESCRIPTION	LENGTH	UNIT WT.	NET WT.
1	1	SPTB-U-F	P-SPTBU-F	UNIVERSAL SLIDING PIPE TIE BACK ASSEMBLY (FRONT CONNECTION ONLY)		19.15	19.15
2	1	SPTB-U-B	P-SPTBU-B	UNIVERSAL SLIDING PIPE TIE BACK ASSEMBLY (REAR CONNECTION ONLY)		33.22	33.22
3	1	P2120		2-3/8" x 120" (2" SCH. 40) GALVANIZED PIPE (A53 Gr.B Fy=35 ksi min.)	120 in	38.81	38.81
						TOTAL WT. #	91.18

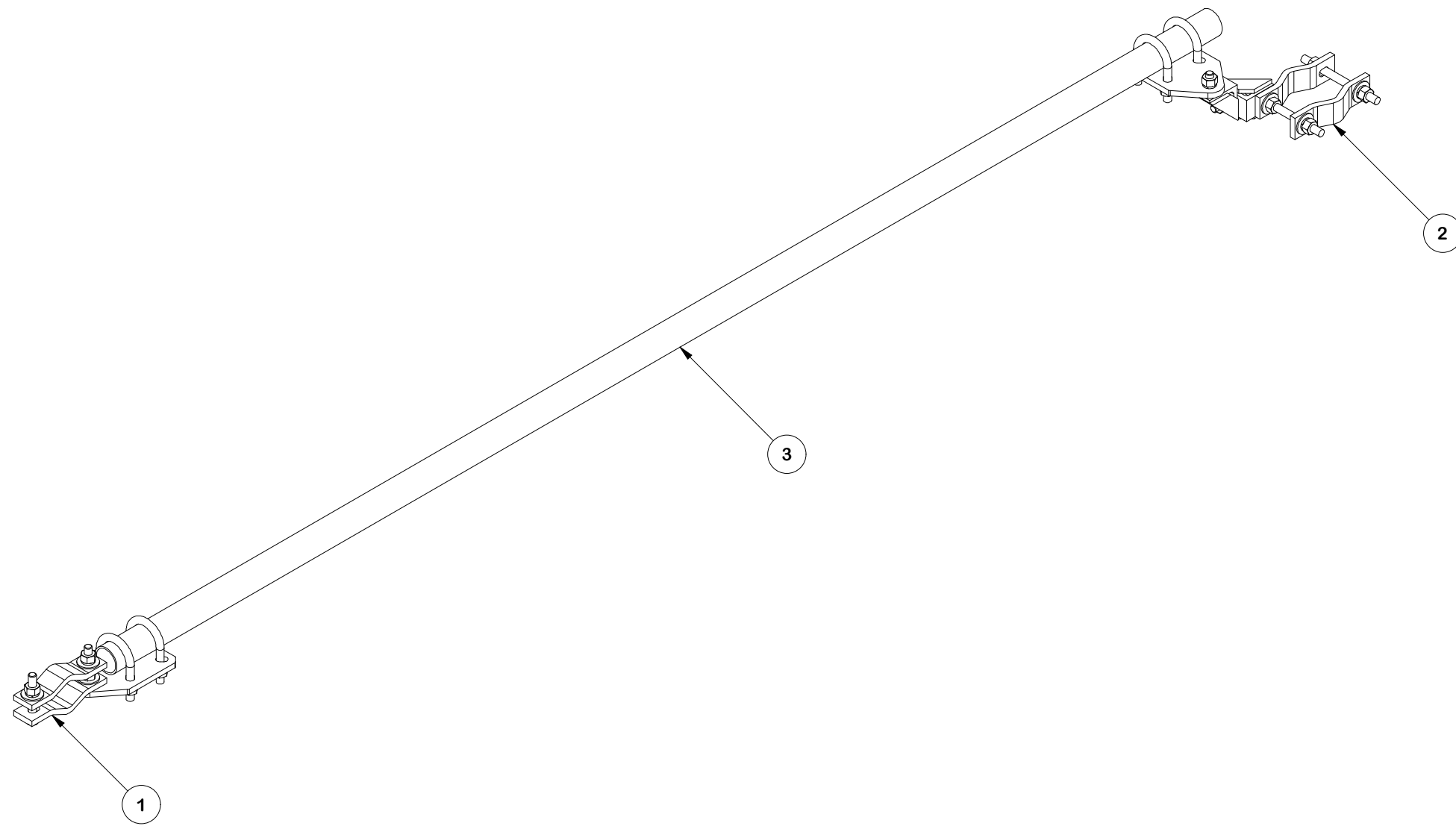

					TOLERANCE NOTES TOLERANCES ON DIMENSIONS, UNLESS OTHERWISE NOTED ARE: SAWED, SHEARED AND GAS CUT EDGES ($\pm 0.030"$) DRILLED AND GAS CUT HOLES ($\pm 0.030"$) - NO CONING OF HOLES LASER CUT EDGES AND HOLES ($\pm 0.010"$) - NO CONING OF HOLES BENDS AND ANGLES ARE $\pm 1/2$ DEGREE ALL OTHER MACHINING ($\pm 0.030"$) ALL OTHER ASSEMBLY ($\pm 0.060"$)			DESCRIPTION HEAVY S3-12-4 3 - 12' NOMINAL SECTOR FRAME KIT WITH SELF-SUPPORTED / GUYED ATTACHMENT			 Engineering Support Team: sp1engineering@valmont.com A valmont COMPANY														
REVISION HISTORY					PATENT INFORMATION: WWW.SITEPRO1.COM/PATENTS			CPD NO. NCS		DRAWN BY ADB 8/19/2025		ENG. APPROVAL 8/22/2025		PART NO. SPTB		PAGE 10 OF 17									
<table border="1"> <thead> <tr> <th>REV</th> <th>DESCRIPTION OF REVISIONS</th> <th>CPD</th> <th>BY</th> <th>DATE</th> </tr> </thead> <tbody> <tr> <td>A</td> <td>REVISED DRAWING & UPDATED X-SPTB TO X-SPTB-U</td> <td>NCS</td> <td>ADB</td> <td>8/8/2024</td> </tr> </tbody> </table>					REV	DESCRIPTION OF REVISIONS	CPD	BY	DATE	A	REVISED DRAWING & UPDATED X-SPTB TO X-SPTB-U	NCS	ADB	8/8/2024	PROPRIETARY NOTE: THE DATA AND TECHNIQUES CONTAINED IN THIS DRAWING ARE PROPRIETARY INFORMATION OF VALMONT INDUSTRIES AND CONSIDERED A TRADE SECRET. ANY USE OR DISCLOSURE WITHOUT THE CONSENT OF VALMONT INDUSTRIES IS STRICTLY PROHIBITED.			CLASS SUB 87 02		DRAWING USAGE CUSTOMER		CHECKED BY JET 8/22/2025		DWG. NO. VFA12-XD3-A12	
REV	DESCRIPTION OF REVISIONS	CPD	BY	DATE																					
A	REVISED DRAWING & UPDATED X-SPTB TO X-SPTB-U	NCS	ADB	8/8/2024																					

RECOMMENDED HORIZONTAL ADJUSTMENT

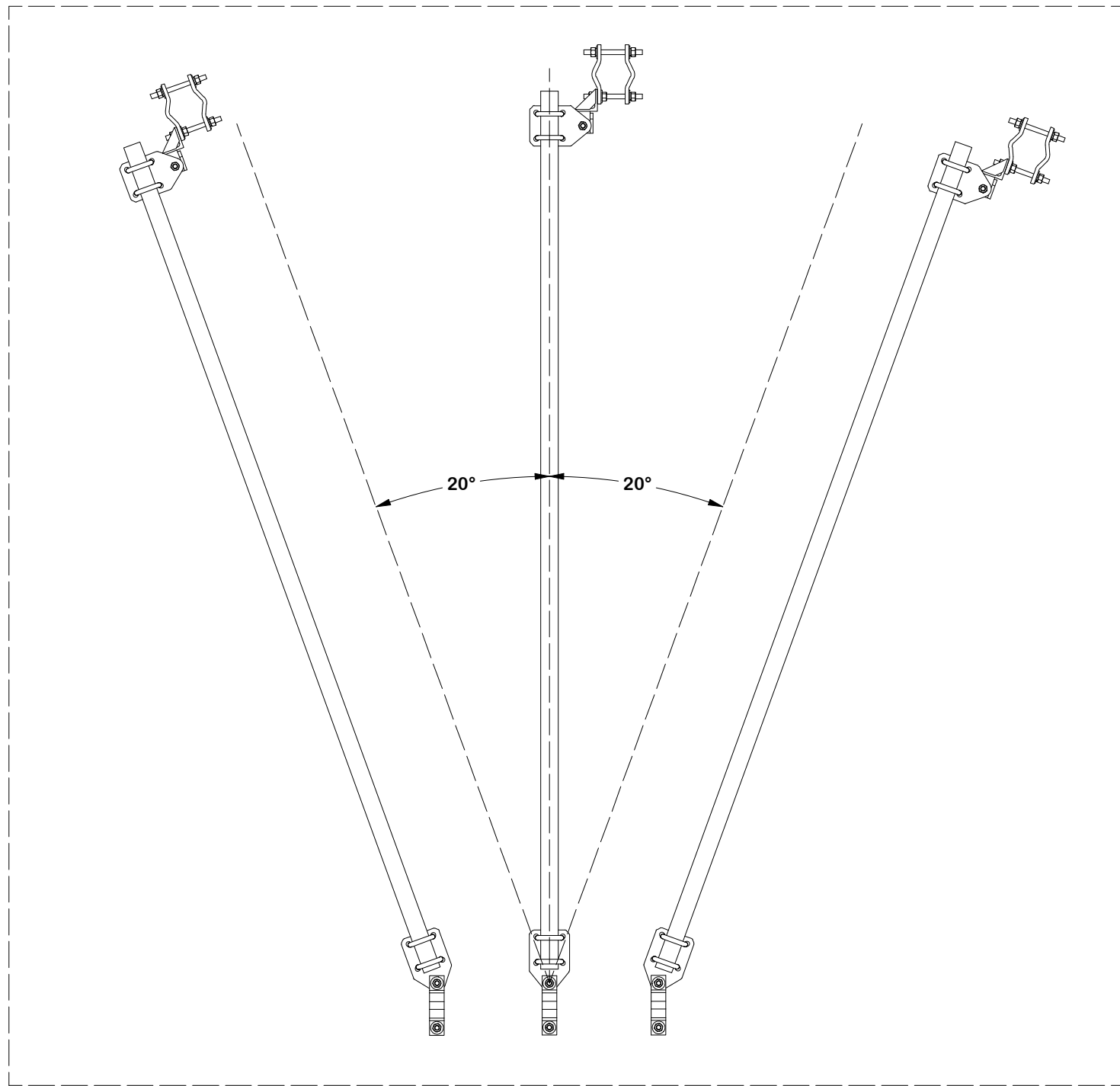

- 20 DEG. 0 DEG. + 20 DEG.

RECOMMENDED VERTICAL ADJUSTMENT

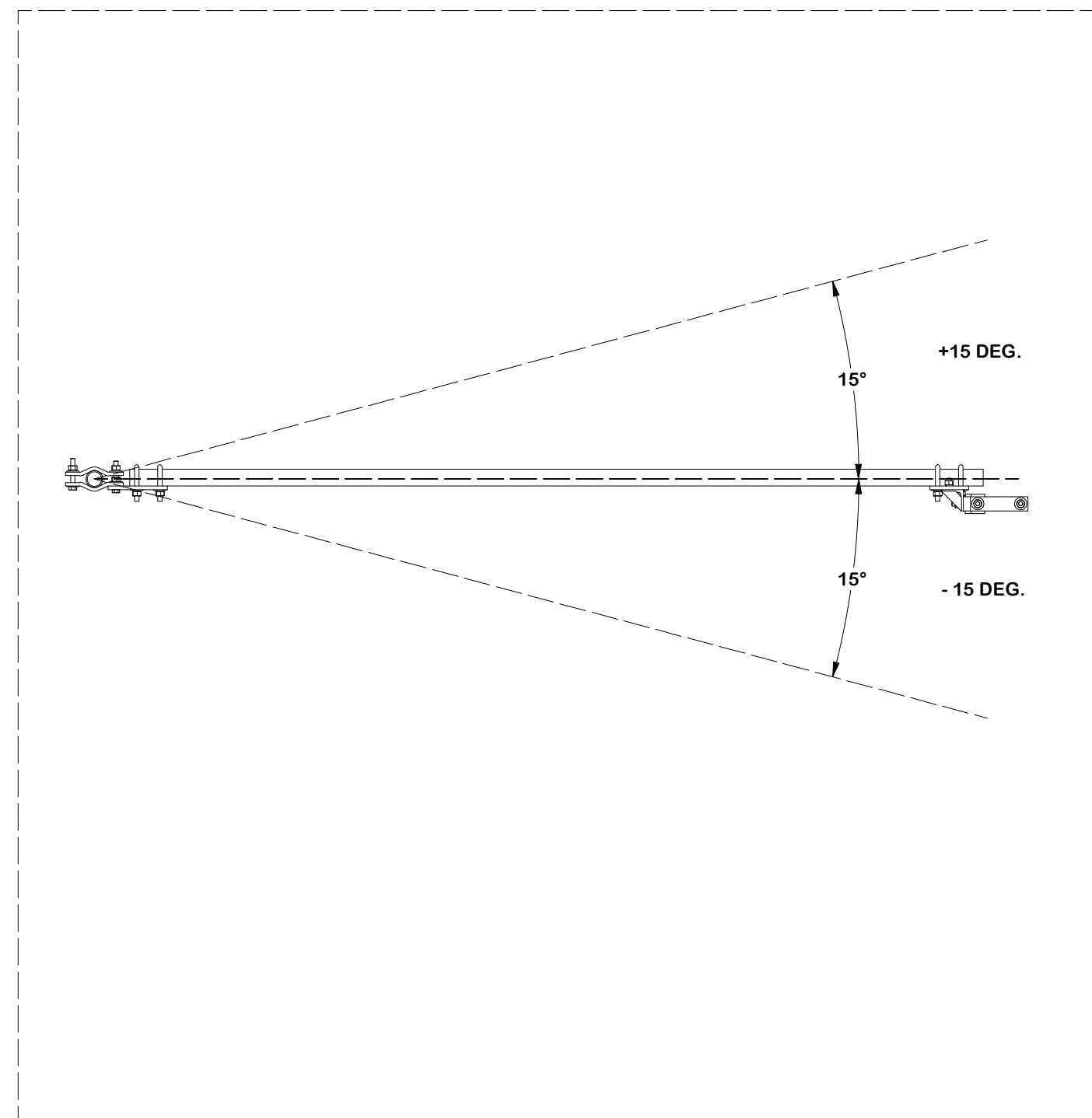

TOLERANCE NOTES

TOLERANCES ON DIMENSIONS, UNLESS OTHERWISE NOTED ARE:
 SAWED, SHEARED AND GAS CUT EDGES ($\pm 0.030"$)
 DRILLED AND GAS CUT HOLES ($\pm 0.030"$) - NO CONING OF HOLES
 LASER CUT EDGES AND HOLES ($\pm 0.010"$) - NO CONING OF HOLES
 BENDS AND ANGLES ARE $\pm 1/2$ DEGREE
 ALL OTHER MACHINING ($\pm 0.030"$)
 ALL OTHER ASSEMBLY ($\pm 0.060"$)

PATENT INFORMATION: WWW.SITEPRO1.COM/PATENTS

PROPRIETARY NOTE:
 THE DATA AND TECHNIQUES CONTAINED IN THIS DRAWING ARE PROPRIETARY INFORMATION OF VALMONT INDUSTRIES AND CONSIDERED A TRADE SECRET. ANY USE OR DISCLOSURE WITHOUT THE CONSENT OF VALMONT INDUSTRIES IS STRICTLY PROHIBITED.

DESCRIPTION
HEAVY S3-12-4
3 - 12' NOMINAL SECTOR FRAME KIT WITH
SELF-SUPPORTED / GUYED ATTACHMENT

CPD NO. NCS	DRAWN BY ADB 8/19/2025	ENG. APPROVAL 8/22/2025
CLASS 87	SUB 02	DRAWING USAGE CUSTOMER
	CHECKED BY JET 8/22/2025	



Engineering Support Team:
 sp1engineering@valmont.com

PART NO. SPTB
DWG. NO. VFA12-XD3-A12

PARTS LIST						
ITEM	QTY	PART NO.	PART DESCRIPTION	LENGTH	UNIT WT.	NET WT.
1	1	X-SPTB-U	SLIDING PIPE TIE BACK PLATE	5 1/2 in	5.58	5.58
2	2	DCP	1/2" THICK, 5-3/4" CNTR TO CENTER CLAMP HALF	8 1/8 in	2.36	4.72
3	2	X-UB5258	5/8 X 2-5/8" X 4-1/2" X 2" U-BOLT	4 1/2 in	1.06	2.12
4	2	X-UB5300	5/8" X 3" X 5-1/4" X 2-1/2" U-BOLT	5 1/4 in	1.22	2.43
5	2	G58R-8	5/8" x 8" THREADED ROD (HDG.)		0.70	1.39
6	2	G5804	5/8" x 4" HDG HEX BOLT GR5		0.44	0.89
7	9	G58FW	5/8" HDG USS FLATWASHER	1/8 in	0.07	0.63
8	8	G58LW	5/8" HDG LOCKWASHER		0.03	0.21
9	9	G58NUT	5/8" HDG HEAVY 2H HEX NUT		0.13	1.17
					TOTAL WT. #	19.15

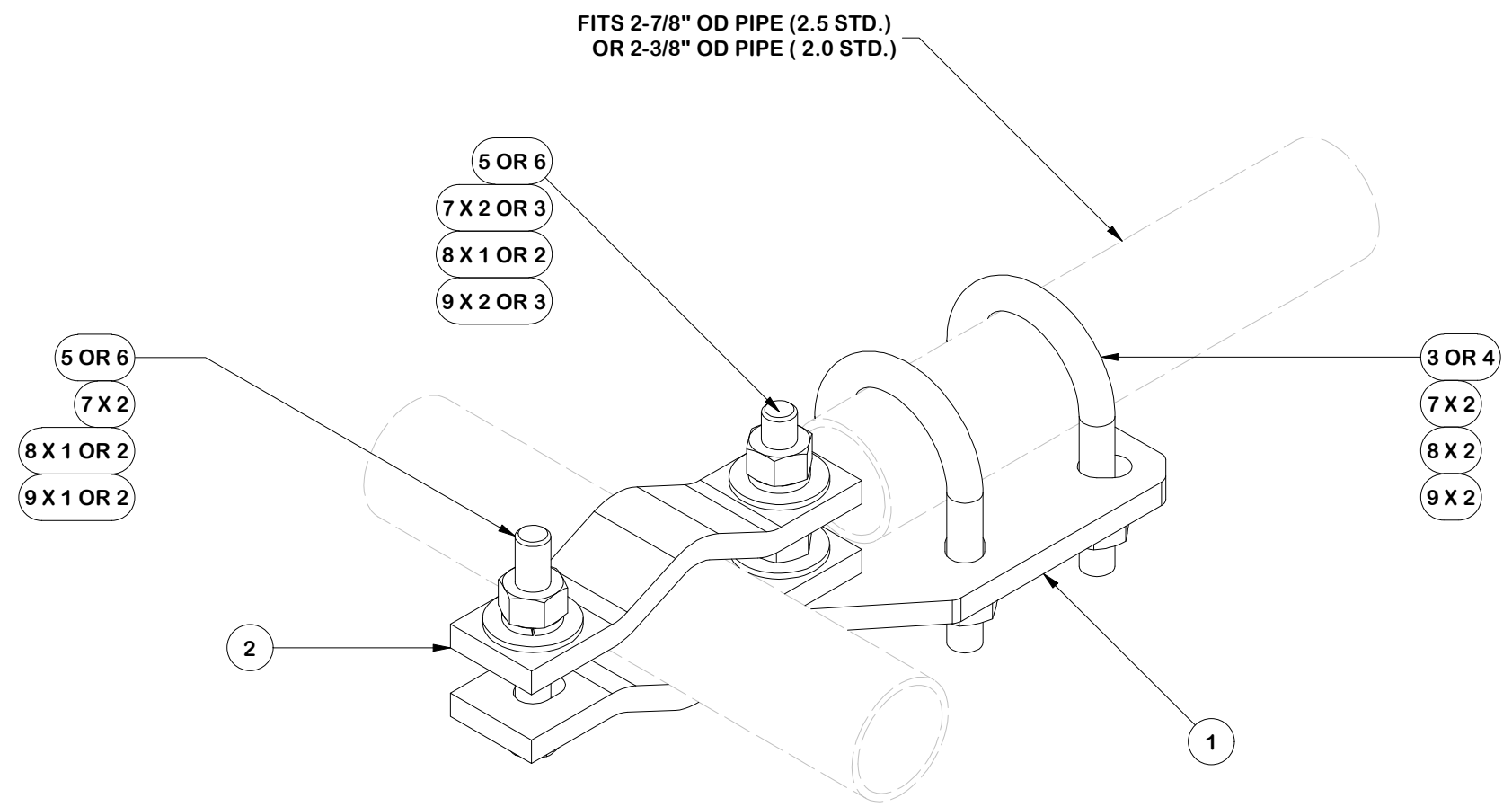

TOLERANCE NOTES

TOLERANCES ON DIMENSIONS, UNLESS OTHERWISE NOTED ARE:
 SAWED, SHEARED AND GAS CUT EDGES ($\pm 0.030"$)
 DRILLED AND GAS CUT HOLES ($\pm 0.030"$) - NO CONING OF HOLES
 LASER CUT EDGES AND HOLES ($\pm 0.010"$) - NO CONING OF HOLES
 BENDS AND ANGLES ARE $\pm 1/2$ DEGREE
 ALL OTHER MACHINING ($\pm 0.030"$)
 ALL OTHER ASSEMBLY ($\pm 0.060"$)

PATENT INFORMATION: WWW.SITEPRO1.COM/PATENTS

PROPRIETARY NOTE:
 THE DATA AND TECHNIQUES CONTAINED IN THIS DRAWING ARE PROPRIETARY INFORMATION OF VALMONT INDUSTRIES AND CONSIDERED A TRADE SECRET. ANY USE OR DISCLOSURE WITHOUT THE CONSENT OF VALMONT INDUSTRIES IS STRICTLY PROHIBITED.

DESCRIPTION
HEAVY S3-12-4
3 - 12' NOMINAL SECTOR FRAME KIT WITH
SELF-SUPPORTED / GUYED ATTACHMENT



Engineering Support Team:
 sp1engineering@valmont.com

CPD NO. **NCS** DRAWN BY **ADB 8/19/2025** ENG. APPROVAL **8/22/2025**

CLASS **87** SUB **02** DRAWING USAGE **CUSTOMER** CHECKED BY **JET 8/22/2025**

PART NO. **SPTB-U-F**

DWG. NO. **VFA12-XD3-A12**

FRONT FACE CONFIGURATIONS

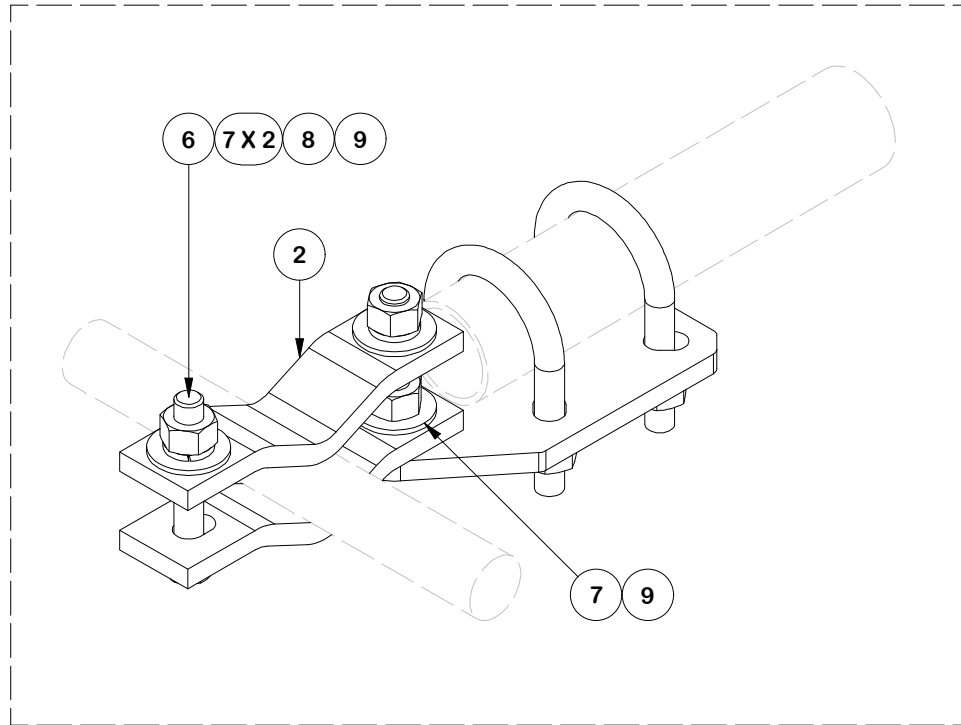

SMALL ATTACHMENT 1-1/2" TO 2-3/8"
NOTE: FLIP HALF BACK CLAMP

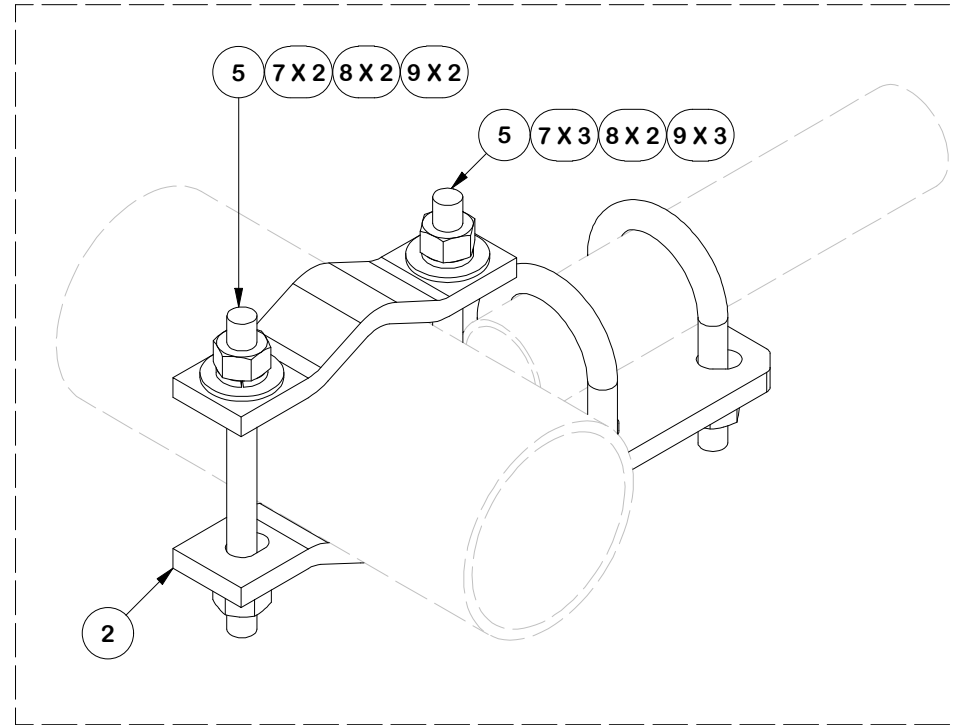

ATTACHMENT 2-3/8" TO 5"
HORIZONTAL ORIENTATION

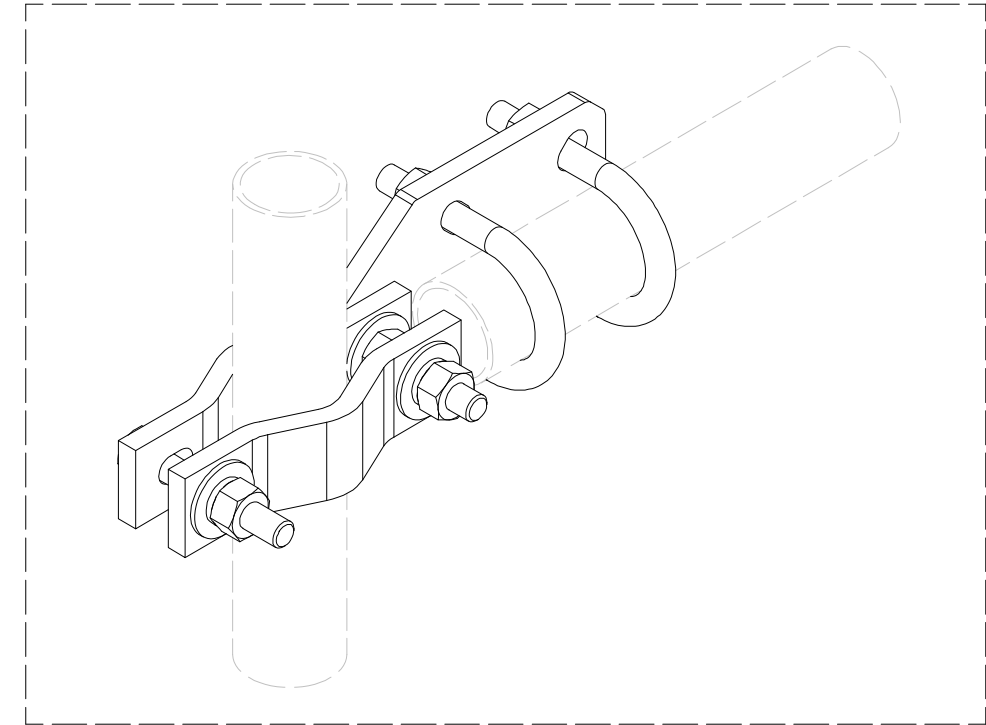

ATTACHMENT 2-3/8" TO 5"
VERTICAL ORIENTATION

TOLERANCE NOTES

TOLERANCES ON DIMENSIONS, UNLESS OTHERWISE NOTED ARE:
 SAWED, SHEARED AND GAS CUT EDGES ($\pm 0.030"$)
 DRILLED AND GAS CUT HOLES ($\pm 0.030"$) - NO CONING OF HOLES
 LASER CUT EDGES AND HOLES ($\pm 0.010"$) - NO CONING OF HOLES
 BENDS AND ANGLES ARE $\pm 1/2$ DEGREE
 ALL OTHER MACHINING ($\pm 0.030"$)
 ALL OTHER ASSEMBLY ($\pm 0.060"$)

PATENT INFORMATION: WWW.SITEPRO1.COM/PATENTS

PROPRIETARY NOTE:
 THE DATA AND TECHNIQUES CONTAINED IN THIS DRAWING ARE PROPRIETARY INFORMATION OF VALMONT INDUSTRIES AND CONSIDERED A TRADE SECRET. ANY USE OR DISCLOSURE WITHOUT THE CONSENT OF VALMONT INDUSTRIES IS STRICTLY PROHIBITED.

DESCRIPTION
HEAVY S3-12-4
3 - 12' NOMINAL SECTOR FRAME KIT WITH
SELF-SUPPORTED / GUYED ATTACHMENT

CPD NO. NCS	DRAWN BY ADB 8/19/2025	ENG. APPROVAL 8/22/2025
CLASS 87	SUB 02	DRAWING USAGE CUSTOMER
	CHECKED BY JET 8/22/2025	



A valmont COMPANY

Engineering Support Team:
 sp1engineering@valmont.com

PART NO. SPTB-U-F
DWG. NO. VFA12-XD3-A12

PARTS LIST						
ITEM	QTY	PART NO.	PART DESCRIPTION	LENGTH	UNIT WT.	NET WT.
1	1	X-SPTB-U	SLIDING PIPE TIE BACK PLATE	5 1/2 in	5.58	5.58
2	2	X-TBCA	TIE BACK CLIP ANGLE		2.01	4.01
3	2	MCP	CLAMP HALF 1/2" THICK, 11-5/8" LONG	12 1/16 in	3.59	7.19
4	2	DCP	1/2" THICK, 5-3/4" CNTR TO CENTER CLAMP HALF	8 1/8 in	2.36	4.72
5	2	X-UB5258	5/8 X 2-5/8" X 4-1/2" X 2" U-BOLT	4 1/2 in	1.06	2.12
6	2	X-UB5300	5/8" X 3" X 5-1/4" X 2-1/2" U-BOLT	5 1/4 in	1.22	2.43
7	2	G58R-12	5/8" x 12" THREADED ROD (HDG.)		1.05	2.09
8	2	G58R-8	5/8" x 8" THREADED ROD (HDG.)		0.70	1.39
9	2	G5804	5/8" x 4" HDG HEX BOLT GR5		0.44	0.89
10	2	G5802	5/8" x 2" HDG HEX BOLT GR5		0.27	0.54
11	8	G58FW	5/8" HDG USS FLATWASHER	1/8 in	0.07	0.56
12	10	G58LW	5/8" HDG LOCKWASHER		0.03	0.26
13	11	G58NUT	5/8" HDG HEAVY 2H HEX NUT		0.13	1.43
					TOTAL WT. #	33.22

FITS 1-1/2" TO 8-5/8" OD TOWER LEGS
60° ANGLE LEGS UP TO 8"
90° ANGLE LEGS UP TO 6"

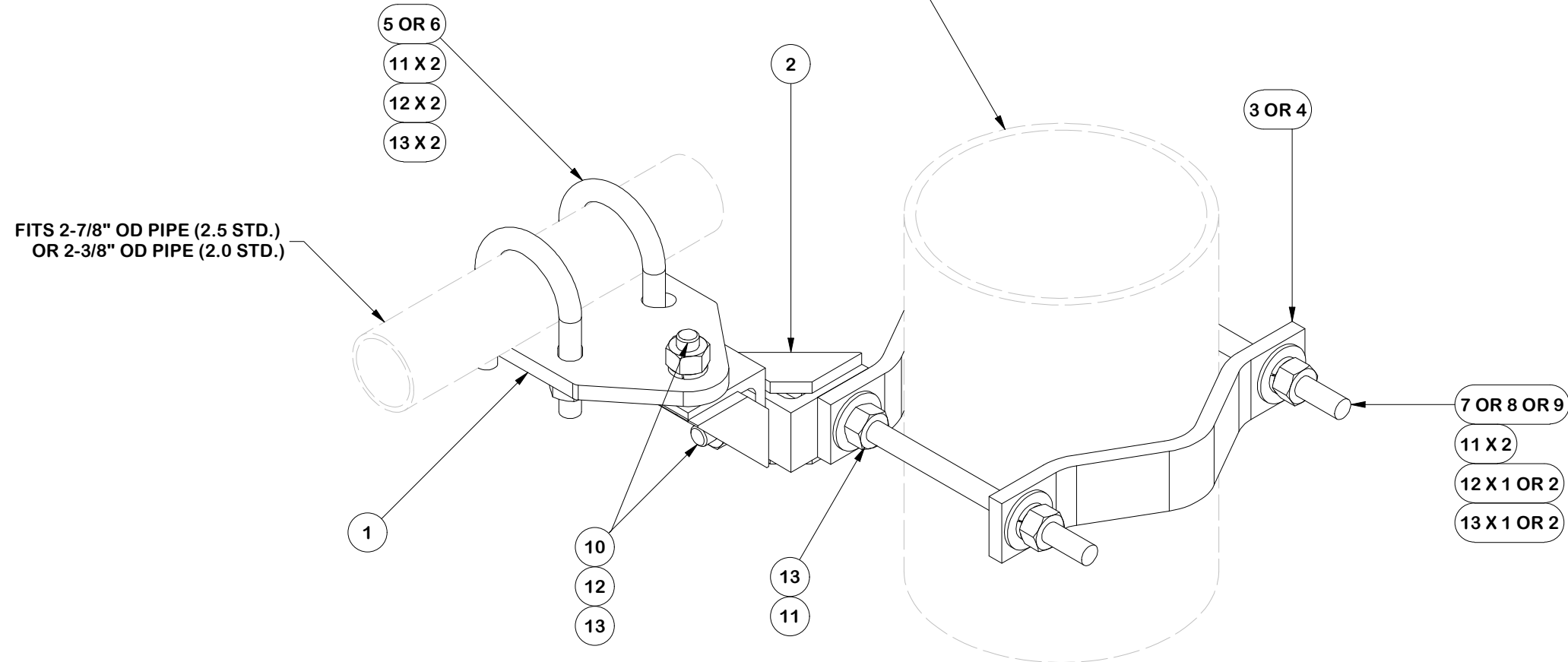

TOLERANCE NOTES

TOLERANCES ON DIMENSIONS, UNLESS OTHERWISE NOTED ARE:
SAWED, SHEARED AND GAS CUT EDGES ($\pm 0.030"$)
DRILLED AND GAS CUT HOLES ($\pm 0.030"$) - NO CONING OF HOLES
LASER CUT EDGES AND HOLES ($\pm 0.010"$) - NO CONING OF HOLES
BENDS AND ANGLES ARE $\pm 1/2$ DEGREE
ALL OTHER MACHINING ($\pm 0.030"$)
ALL OTHER ASSEMBLY ($\pm 0.060"$)

PATENT INFORMATION: WWW.SITEPRO1.COM/PATENTS

PROPRIETARY NOTE:
THE DATA AND TECHNIQUES CONTAINED IN THIS DRAWING ARE PROPRIETARY INFORMATION OF VALMONT INDUSTRIES AND CONSIDERED A TRADE SECRET. ANY USE OR DISCLOSURE WITHOUT THE CONSENT OF VALMONT INDUSTRIES IS STRICTLY PROHIBITED.

DESCRIPTION
**HEAVY S3-12-4
3 - 12' NOMINAL SECTOR FRAME KIT WITH
SELF-SUPPORTED / GUYED ATTACHMENT**

CPD NO. NCS	DRAWN BY ADB 8/19/2025	ENG. APPROVAL 8/22/2025
CLASS 87	SUB 02	DRAWING USAGE CUSTOMER
CHECKED BY JET 8/22/2025		



Engineering Support Team:
sp1engineering@valmont.com

PART NO. SPTB-U-B	PAGE 14 OF 17
DWG. NO. VFA12-XD3-A12	

TOWER LEG CONFIGURATIONS

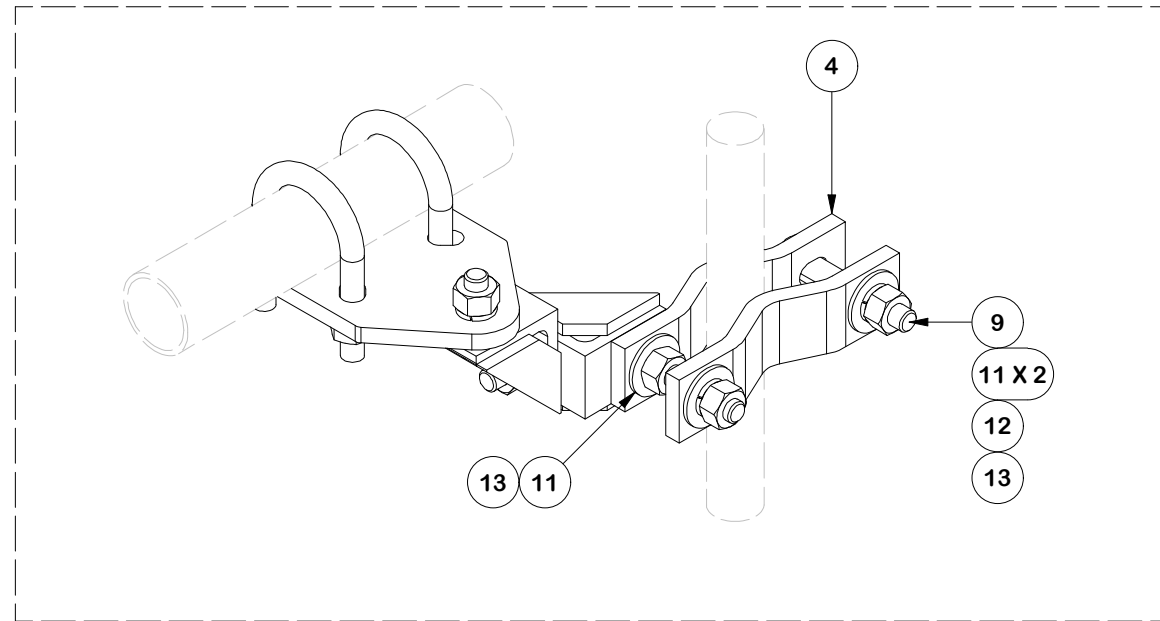

SMALL LEGS 1-1/2" TO 2-3/8"
NOTE: FLIP HALF BACK CLAMP

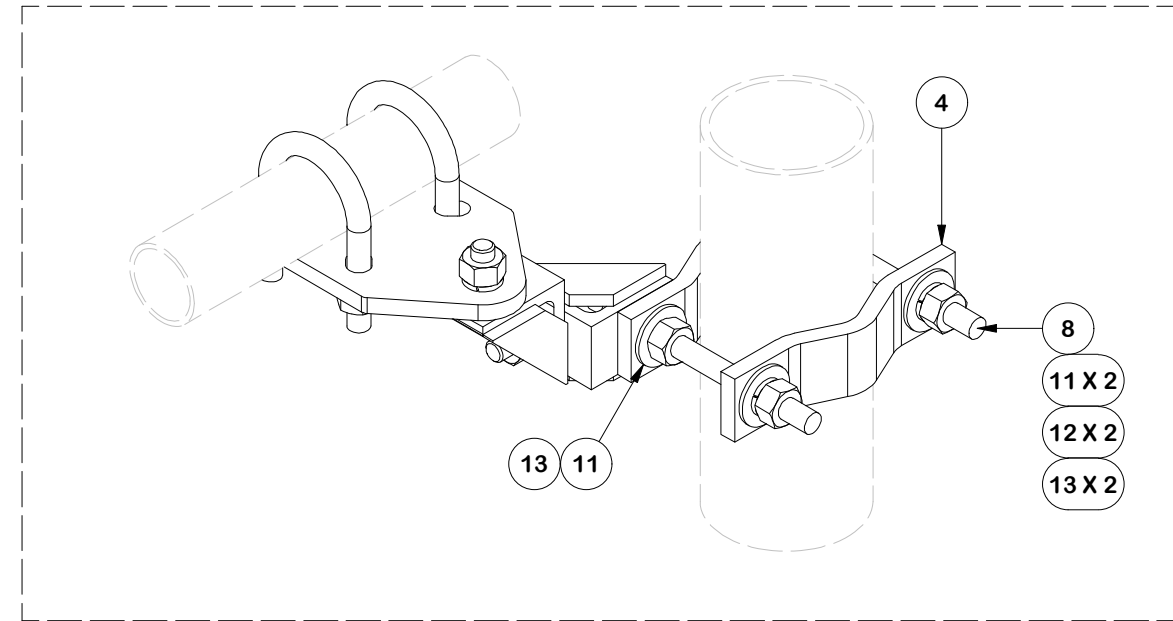

MEDIUM LEGS 2-7/8" TO 5"
NOTE: FLIP HALF BACK CLAMP FOR ANGLE

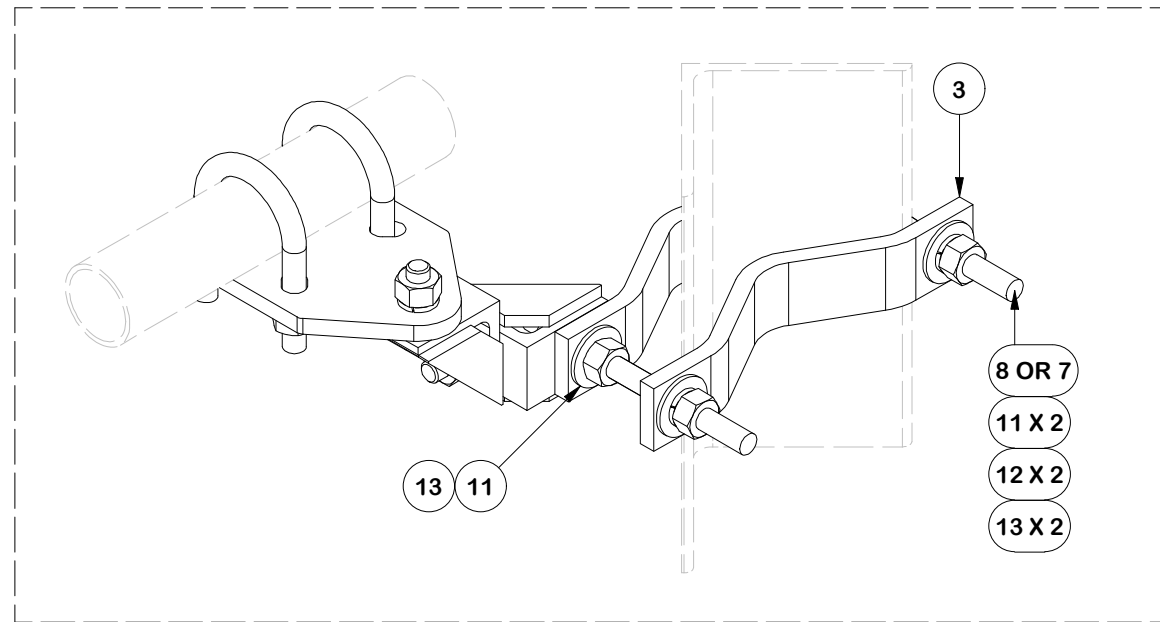

LARGE LEGS UP TO 6" 90 DEG. 8" 60 DEG
NOTE: FLIP HALF BACK CLAMP

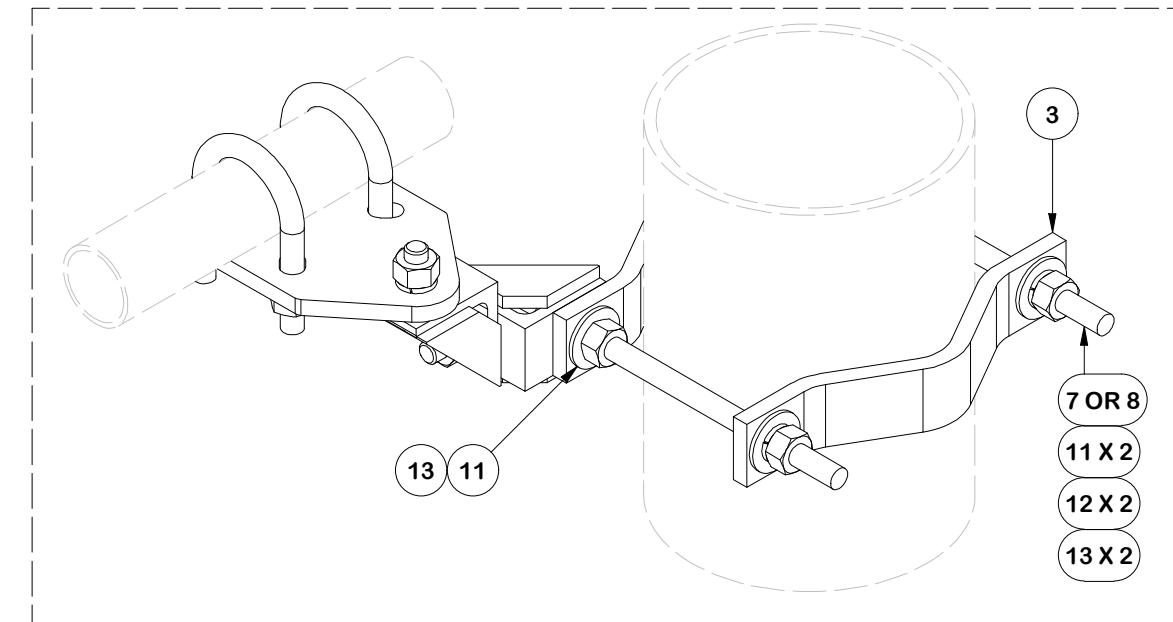

LARGE LEGS 5" TO 8-5/8" OD

TOLERANCE NOTES

TOLERANCES ON DIMENSIONS, UNLESS OTHERWISE NOTED ARE:
 SAWED, SHEARED AND GAS CUT EDGES ($\pm 0.030"$)
 DRILLED AND GAS CUT HOLES ($\pm 0.030"$) - NO CONING OF HOLES
 LASER CUT EDGES AND HOLES ($\pm 0.010"$) - NO CONING OF HOLES
 BENDS AND ANGLES ARE $\pm 1/2$ DEGREE
 ALL OTHER MACHINING ($\pm 0.030"$)
 ALL OTHER ASSEMBLY ($\pm 0.060"$)

PATENT INFORMATION: WWW.SITEPRO1.COM/PATENTS

PROPRIETARY NOTE:
 THE DATA AND TECHNIQUES CONTAINED IN THIS DRAWING ARE PROPRIETARY INFORMATION OF VALMONT INDUSTRIES AND CONSIDERED A TRADE SECRET. ANY USE OR DISCLOSURE WITHOUT THE CONSENT OF VALMONT INDUSTRIES IS STRICTLY PROHIBITED.

DESCRIPTION
HEAVY S3-12-4
3 - 12' NOMINAL SECTOR FRAME KIT WITH
SELF-SUPPORTED / GUYED ATTACHMENT

CPD NO. NCS	DRAWN BY ADB 8/19/2025	ENG. APPROVAL 8/22/2025
CLASS 87	SUB 02	DRAWING USAGE CUSTOMER
	CHECKED BY JET 8/22/2025	



Engineering Support Team:
 sp1engineering@valmont.com

PART NO. SPTB-U-B
DWG. NO. VFA12-XD3-A12

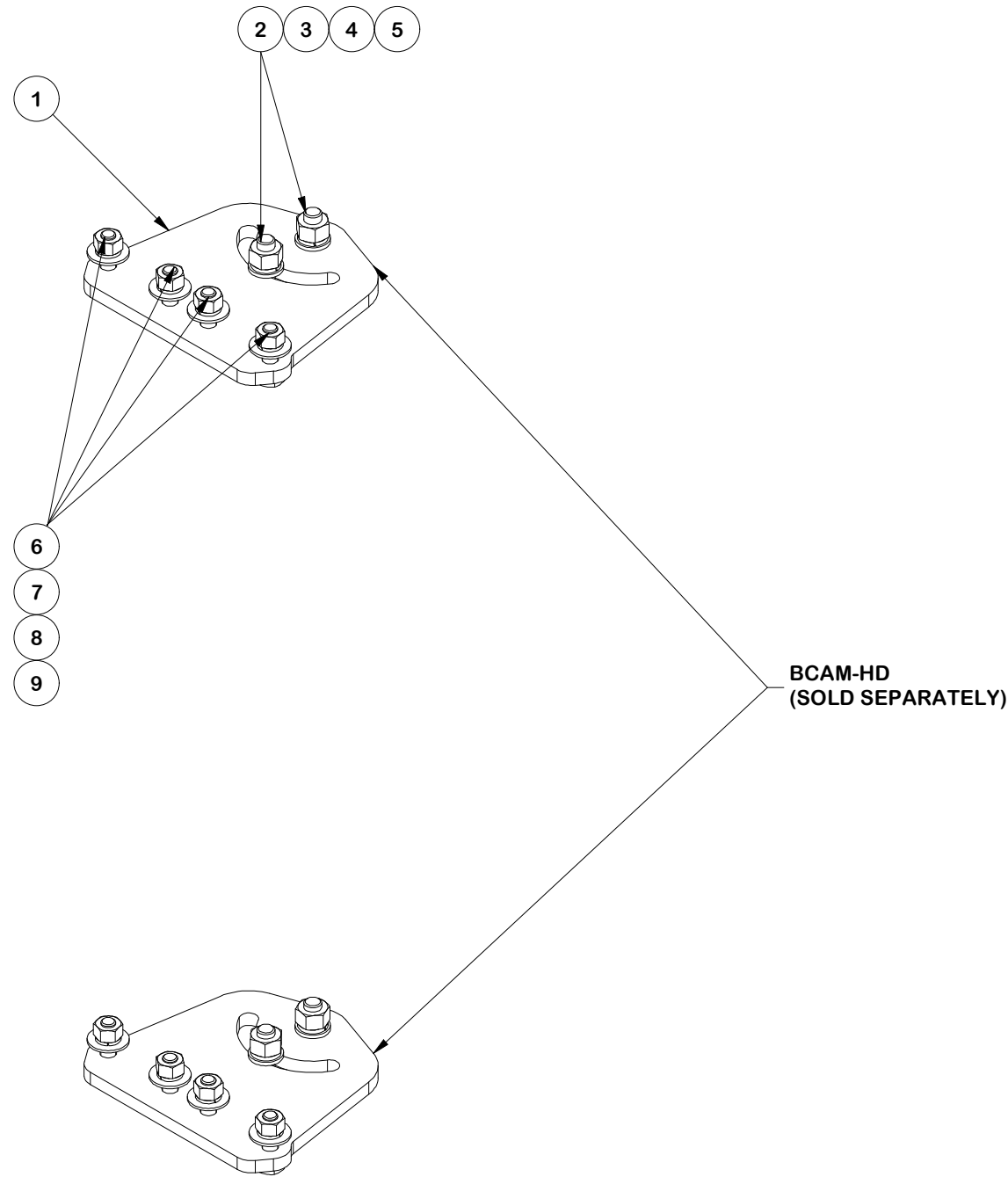

PARTS LIST						
ITEM	QTY	PART NO.	PART DESCRIPTION	LENGTH	UNIT WT.	NET WT.
1	2	X-VFAPL4	VFA-HD PIVOT PLATE	12 in	15.88	31.77
2	4	A34212	3/4" x 2-1/2" UNC HEX BOLT (A325)	2 1/2 in	0.48	1.92
3	4	G34FW	3/4" HDG USS FLATWASHER		0.06	0.24
4	4	G34LW	3/4" HDG LOCKWASHER		0.04	0.17
5	4	G34NUT	3/4" HDG HEAVY 2H HEX NUT		0.21	0.85
6	8	A582114	5/8" x 2-1/4" HDG A325 HEX BOLT	2 1/4 in	0.31	2.50
7	8	G58FW	5/8" HDG USS FLATWASHER	1/8 in	0.07	0.56
8	8	G58LW	5/8" HDG LOCKWASHER		0.03	0.21
9	8	G58NUT	5/8" HDG HEAVY 2H HEX NUT		0.13	1.04
					TOTAL WT. #	39.25

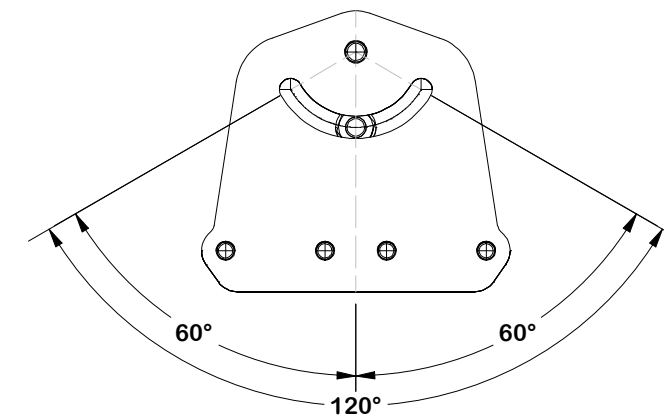

PIVOT RANGE

FINISH:
HOT DIP GALVANIZED.

TOLERANCE NOTES

TOLERANCES ON DIMENSIONS, UNLESS OTHERWISE NOTED ARE:
 SAWED, SHEARED AND GAS CUT EDGES ($\pm 0.030"$)
 DRILLED AND GAS CUT HOLES ($\pm 0.030"$) - NO CONING OF HOLES
 LASER CUT EDGES AND HOLES ($\pm 0.010"$) - NO CONING OF HOLES
 BENDS AND ANGLES ARE $\pm 1/2$ DEGREE
 ALL OTHER MACHINING ($\pm 0.030"$)
 ALL OTHER ASSEMBLY ($\pm 0.060"$)

PATENT INFORMATION: WWW.SITEPRO1.COM/PATENTS

PROPRIETARY NOTE:
 THE DATA AND TECHNIQUES CONTAINED IN THIS DRAWING ARE PROPRIETARY INFORMATION OF VALMONT INDUSTRIES AND CONSIDERED A TRADE SECRET. ANY USE OR DISCLOSURE WITHOUT THE CONSENT OF VALMONT INDUSTRIES IS STRICTLY PROHIBITED.

DESCRIPTION
HEAVY S3-12-4
3 - 12' NOMINAL SECTOR FRAME KIT WITH
SELF-SUPPORTED / GUYED ATTACHMENT

CPD NO. NCS	DRAWN BY ADB 8/19/2025	ENG. APPROVAL 8/22/2025
CLASS 87	SUB 02	DRAWING USAGE CUSTOMER
CHECKED BY JET 8/22/2025		



A valmont COMPANY

Engineering
 Support Team:
 sp1engineering@valmont.com

PART NO. VFAPL4-K	PAGE 16 OF 17
DWG. NO. VFA12-XD3-A12	

PARTS LIST						
ITEM	QTY	PART NO.	PART DESCRIPTION	LENGTH	UNIT WT.	NET WT.
1	1	SCX2	CROSSOVER PLATE	7 in	5.08	5.08
2	4	X-UB1300	1/2 X 3" X 5" X 2" U-BOLT	5 in	0.74	2.95
3	8	G12NUT	1/2" HDG HEAVY 2H HEX NUT	7/8 in	0.07	0.57
4	8	G12FW	1/2" HDG USS FLATWASHER	3/32 in	0.03	0.27
5	8	G12LW	1/2" HDG LOCKWASHER	1/8 in	0.01	0.11
					TOTAL WT. #	8.40

2-7/8" O.D. ANTENNA PIPE
(ORDERED SEPARATELY)

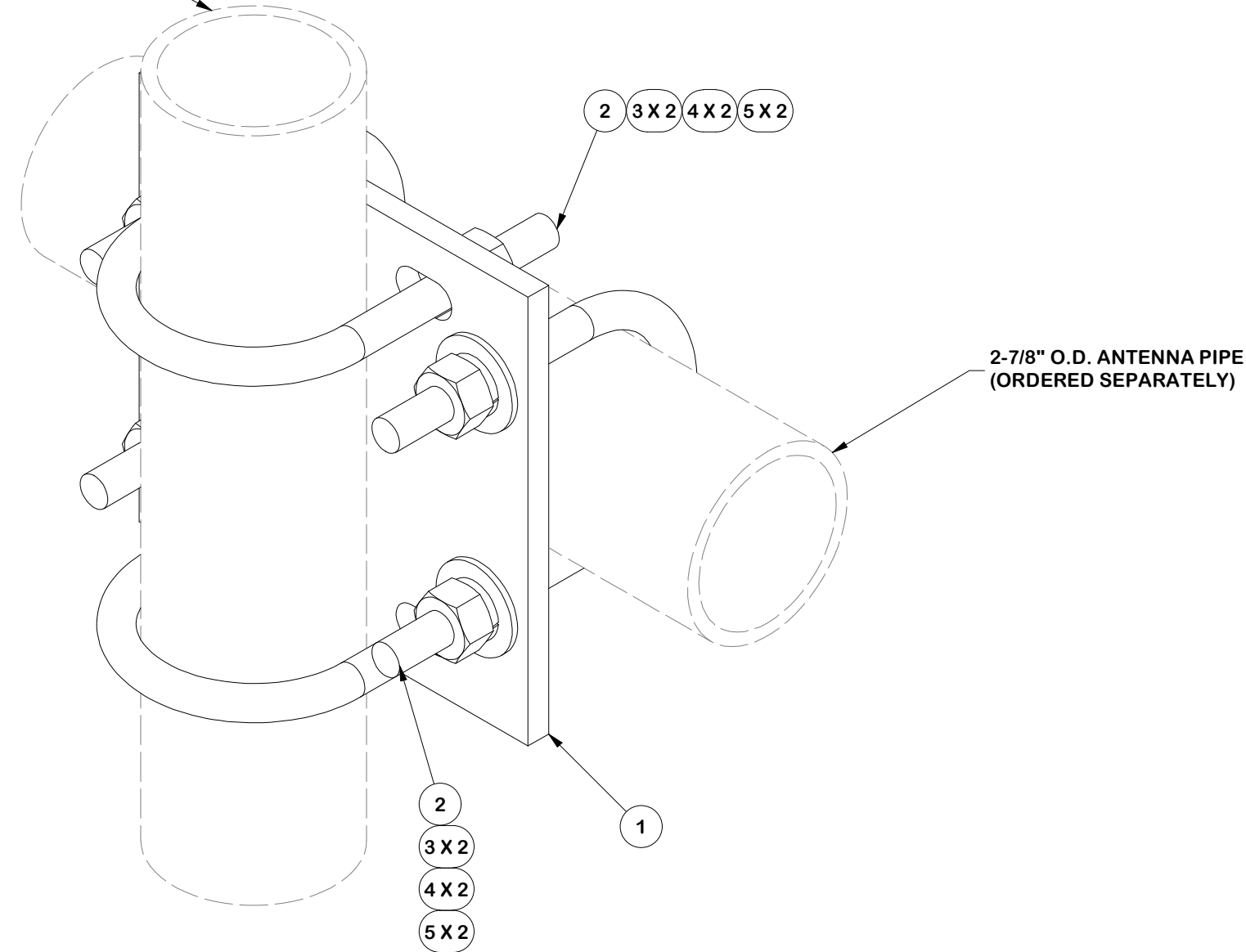

TOLERANCE NOTES

TOLERANCES ON DIMENSIONS, UNLESS OTHERWISE NOTED ARE:
 SAWED, SHEARED AND GAS CUT EDGES ($\pm 0.030"$)
 DRILLED AND GAS CUT HOLES ($\pm 0.030"$) - NO CONING OF HOLES
 LASER CUT EDGES AND HOLES ($\pm 0.010"$) - NO CONING OF HOLES
 BENDS AND ANGLES ARE $\pm 1/2$ DEGREE
 ALL OTHER MACHINING ($\pm 0.030"$)
 ALL OTHER ASSEMBLY ($\pm 0.060"$)

PATENT INFORMATION: WWW.SITEPRO1.COM/PATENTS

PROPRIETARY NOTE:
 THE DATA AND TECHNIQUES CONTAINED IN THIS DRAWING ARE PROPRIETARY INFORMATION OF VALMONT INDUSTRIES AND CONSIDERED A TRADE SECRET. ANY USE OR DISCLOSURE WITHOUT THE CONSENT OF VALMONT INDUSTRIES IS STRICTLY PROHIBITED.

DESCRIPTION
HEAVY S3-12-4
3 - 12' NOMINAL SECTOR FRAME KIT WITH
SELF-SUPPORTED / GUYED ATTACHMENT



Engineering Support Team:
 sp1engineering@valmont.com

CPD NO.	DRAWN BY	ENG. APPROVAL
NCS	ADB 8/19/2025	8/22/2025
CLASS	DRAWING USAGE	CHECKED BY
87	CUSTOMER	JET 8/22/2025

PART NO.	SCX23-K
DWG. NO.	VFA12-XD3-A12